

# **K** monogirante



## APPLICATIONS



## NOMENCLATURA PARTI DI RICAMBIO SPARE PARTS LIST NOMENCLATURE PIÈCES DE RECHANGE NOMENCLATURA REPUESTOS

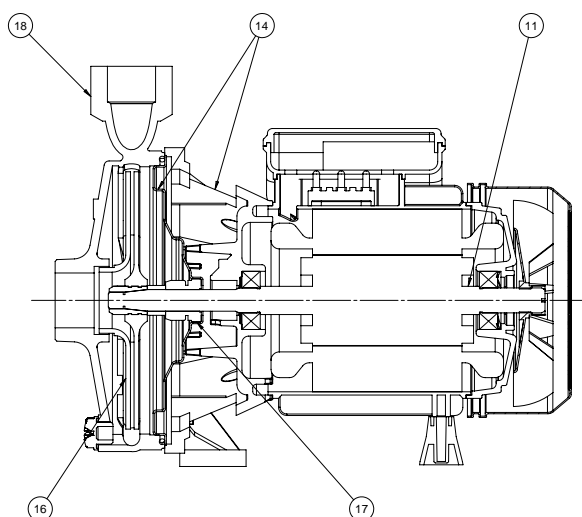

Albero con rotore – Pump shaft + rotor Arbre + rotor – Eje rotor	<b>11</b>
Supporto mandata – Outlet bracket Support envoyée – Soporte entrega	<b>14</b>
Girante – Impeller Turbine – Impulsor	<b>16</b>
Tenuta meccanica – Mechanical seal Garniture mécanique – Cierre mecánico	<b>17</b>
Corpo pompa – Pump body Corp de pompe – Cuerpo bomba	<b>18</b>

### ELETTROPOMPE CENTRIFUGHE MONOGIRANTE

Le elettropompe centrifughe monogiranti della serie K, sono state progettate per pompare liquidi, senza parti abrasive, senza corpi solidi in sospensione, non esplosivi o aggressivi per i materiali della pompa.

- Temperatura del liquido fino a 35 °C per uso domestico (CEI EN 60335-2-41) o 90 °C per altri usi e temperatura ambiente fino a 40 °C
- Portate fino a 18 m<sup>3</sup>/h
- Prevalenze fino a ~ 60 m.

### CARATTERISTICHE COSTRUTTIVE

Corpo pompa	Ghisa G20 con trattamento anticorrosione
Supporto motore	Alluminio pressofuso UNI 5076 (ghisa per K 150-550)
Girante:	Tecnopolimero (ottone stampato UNI- EN 12165 per K 150-550)
Albero pompa	Acciaio inox AISI 304 (AISI 420 F per K 50-100)
Tenuta meccanica	Carbone - Ceramica

### MOTORE

I motori di comando sono del tipo asincrono a gabbia di scoiattolo chiusi, a ventilazione esterna.

- Motoprotettore incorporato e condensatore permanentemente inserito per i tipi monofasi
- La protezione del motore nella versione trifase è a cura del cliente e si raccomandano apparecchiature in accordo con le norme vigenti
- Isolamento classe F
- Servizio S1
- Grado di protezione IP 44
- Protezione morsettiera IP 54.

### ÉLECTROPOMPES CENTRIFUGES À UNE ROUE

Les électropompes centrifuges à une roue de la série K, ont été conçues pour pomper des liquides, sans parties abrasives, sans corps liquides en suspension, non explosifs ou agressifs pour les matériaux de la pompe.

- Température max. du liquide jusqu'à 35 °C pour utilisation domestique (CEI EN 60335-2-41) ou 90 °C pour d'autres utilisations et température ambiante jusqu'à 40 °C
- Plage d'utilisation jusqu'à 18 m<sup>3</sup>/h
- Hauteur manométrique jusqu'à ~ 60 m.

### CARACTERISTIQUES DE CONSTRUCTION

Corps de pompe	En fonte G20 avec traitement anti-corrosion
Lanterne	Fonderie d'aluminium sous pression UNI 5076 (en fonte pour K 150÷550)
Turbine	Techonopolymère (laiton étampé UNI- EN 12165 pour K 150-550)
Abre de pompe	Acier inox AISI 304 (AISI 420 F pour K 50-100)
Garniture mécanique	Carbone - Céramique

### MOTOR

Les moteurs sont asynchrones à cage d'écurieil fermés à ventilation extérieure monofásicos.

- Pour les modèles monophasé son avec protection thermique et condensateur connecté en permanence
- Pour les modèles triphasés, la protection est à la charge de l'utilisateur. A recommandé l'équipement conformément à la réglementation
- A Classe d'isolation F
- Service S 1
- Protection IP44
- Protection IP54 dans le terminal.

### CENTRIFUGAL ELECTRIC PUMPS ONE IMPELLER

The close-coupled centrifugal electric pumps with one impeller series K have been designed to pump clear liquids, without abrasives and suspended solids, non-explosive or aggressive for the pump's materials.

- Liquid temperature not higher than 35 °C for domestic use (CEI EN 60335-2-41) or 90 °C for other use, while the ambient temperature must not be higher than 40 °C
- Flow rate up to ~ 18 m<sup>3</sup>/h
- Heads up to ~ 60 m.

### TECHNICAL FEATURES

Pump body	Cast iron G20 with anti-corrosive coating
Motor bracket	In die casting aluminium UNI 5076 (cast iron for K 150-550)
Impeller	Techno-polymer (stamped brass UNI- EN 12165 for K 150-550)
Pump shaft	Stainless steel AISI 304 (AISI 420 F for K 50-100)
Mechanical seal	Carbon - Ceramics

### MOTOR

The control motors are asynchronous, squirrel cage-type, closed, with external ventilation.

- Incorporated motor protection and capacitor always on, for single-phase models
- The motor protection for three-phase models must be installed by the customer. Equipment compliant with current standards should be used
- Class of insulation F
- service S1
- Degree of protection IP 44
- Terminal board protection IP 54.

### ELECTROBOMBAS CENTRÍFUGAS MONOIMPULSOR

Las electrobombas centrífugas con monoimpulsor de la serie K, han sido proyectadas para bombear líquidos, sin partes abrasivas, sin cuerpos sólidos en suspensión, que no sean explosivos ni agresivos para los materiales de la bomba.

- Temperatura max. del líquido hasta 35 °C para uso doméstico (CEI EN 60335-2-41) o 90 °C para otros usos y temperatura ambiente hasta 40 °C
- Caudal hasta 18 m<sup>3</sup>/h
- Alturas hasta ~ 60 m.

### CARACTERÍSTICAS DE CONSTRUCCIÓN

Cuerpo de bomba	Fundición gris G20 con tratamiento contra-corrosión
Soporte	Fundición de aluminio UNI 5076 (Fundición gris para las K 150÷550)
Rodete	Tecnopolímero (De latón UNI- EN 12165 para las 150÷550)
Eje de la bomba	Acero Inox AISI 304 (AISI 420 F para las K 50÷100)
Cierre mecánico	Cerámica - Grafito

### MOTOR

Los motores de accionamiento son asíncrono de jaula de ardilla cerrados, ventilados externamente.

- Para los modelos monofásicos, protección térmica y condensador incorporado
- Para los modelos trifásicos se encarga el usuario de la protección del motor y se recomienda un equipo de acuerdo con las normas vigentes
- Aislamiento de Clase F
- funcionamiento S1
- Protección IP44
- Protección IP54 para el terminal.

50 Hz - min<sup>-1</sup> ~ 2900

TIPO TYPE		Potenza nominale Nominal power		Potenza assorbita Input power [W]		Condensatore Capacitor 450 V max	Corrente assorbita Input current [A]			Portata - Capacity																	
Monofase Single-phase	Trifase Three-phase	kW	HP	a	b	[μF]	1~230V	3~230V	3~400V	Q [m <sup>3</sup> /h]	0	1,2	2,4	3,6	4,8	6	7,8	Q [l/s]	0	20	40	60	80	100	130		
a	b									Prevalenza (m C.A.) Total head (m W.C.)																	
<b>K 50 M</b>	<b>K 50 T</b>	0,37	0,5	680	710	12,5	2,6	1,9	1,1	H [m]	20,0	19,5	18,0	16,0	12,5	8,5											
<b>K 80 M</b>	<b>K 80 T</b>	0,6	0,8	1170	1040	16	4,8	3,2	1,8		30,0	29,0	28,0	25,5	22,5	18											
<b>K 100 M</b>	<b>K 100 T</b>	0,74	1	1450	1490	25	5,8	4	2,3		33,0	32,0	30,5	28,0	25,0	20,5	12,5										

a) ~ Monofase 230 V

b) ~ Trifase 230/400 V

TIPO TYPE		Potenza nominale Nominal power		Potenza assorbita Input power [W]		Condensatore Capacitor 450 V max	Corrente assorbita Input current [A]			Portata - Capacity																
Monofase Single-phase	Trifase Three-phase	kW	HP	a	b	[μF]	1~230V	3~230V	3~400V	Q [m <sup>3</sup> /h]	0	2,4	4,8	7,2	9	10,2	10,8	Q [l/s]	0	40	80	120	150	170	180	
a	b									Prevalenza (m C.A.) Total head (m W.C.)																
<b>K 151 M</b>	<b>K 151 T</b>	1,1	1,5	1980	1990	31,5	9	6	3,5	H [m]	41,0	40,0	36,8	30,0	20,0											
<b>K 200 M</b>	<b>K 200 T</b>	1,47	2	2730	2630	36	12	8,3	4,8		47,4	45,9	41,3	33,7	24,2	16,1	10									
<b>K 300 M</b>	<b>K 300 T</b>	2,2	3	3100	2970	55	13,6	8,9	5,1		52,9	51,5	47,2	40,1	32,8	24	19,5									

a) ~ Monofase 230 V

b) ~ Trifase 230/400 V

TIPO TYPE		Potenza nominale Nominal power		Potenza assorbita Input power [W]		Condensatore Capacitor 450 V max	Corrente assorbita Input current [A]			Portata - Capacity															
Monofase Single-phase	Trifase Three-phase	kW	HP	a	b	[μF]	1~230V	3~230V	3~400V	Q [m <sup>3</sup> /h]	0	3	6	9	12	15	18	Q [l/s]	0	50	100	150	200	250	300
a	b									Prevalenza (m C.A.) Total head (m W.C.)															
<b>K 400 M</b>	<b>K 400 T</b>	3	4	4180	4470	70	18	13,5	7,8	H [m]	48,5	48,0	48,0	46,0	42,0	38	32								
-	<b>K 550 T</b>	4	5,5	-	5860	-	-	19	10,2		61,0	61,0	60,0	59,0	57,0	54	49,5								

a) ~ Monofase 230 V

b) ~ Trifase 230/400 V

60 Hz - min<sup>-1</sup> ~ 3400

TIPO TYPE		Potenza nominale Nominal power		Potenza assorbita Input power [W]		Condensatore Capacitor 450 V max	Corrente assorbita Input current [A]				Portata - Capacity															
Monofase Single-phase	Trifase Three-phase	kW	HP	a	b	[μF]	1~115V	1~220V	3~220V	3~380V	Q [m <sup>3</sup> /h]	0	1,2	2,4	3,6	4,8	6	7,8	Q [l/s]	0	20	40	60	80	100	130
a	b										Prevalenza (m C.A.) Total head (m W.C.)															
<b>K 50 M</b>	<b>K 50 T</b>	0,37	0,5	720	760	16	6,6	2,2	2,1	1,3	H [m]	21,5	20,6	19,0	16,9	13,6	10,3									
<b>K 80 M</b>	<b>K 80 T</b>	0,6	0,8	1160	1190	20	9,5	3,2	3,3	1,8		31,5	30,0	28,0	26,0	24,0	19,0									
<b>K 100 M</b>	<b>K 100 T</b>	0,74	1	1230	1520	20	13	4	2,3			33,5	32,5	31,0	29,0	27,0	24	16								

a) ~ Monofase 115/220 V

b) ~ Trifase 220/380 V

TIPO TYPE		Potenza nominale Nominal power		Potenza assorbita Input power [W]		Condensatore Capacitor 450 V max	Corrente assorbita Input current [A]			Portata - Capacity															
Monofase Single-phase	Trifase Three-phase	kW	HP	a	b	[μF]	1~220V	3~220V	3~380V	Q [m <sup>3</sup> /h]	0	2,4	4,8	7,2	9	10,2	10,8	Q [l/s]	0	40	80	120	150	170	180
a	b									Prevalenza (m C.A.) Total head (m W.C.)															
<b>K 151 M</b>	<b>K 151 T</b>	1,1	1,5	1990	2120	31,5	6	6,9	3,5	H [m]	38,0	37,8	35,0	26,0	12,5										
<b>K 201 M</b>	<b>K 201 T</b>	1,47	2	2500	2630	45	11,5	7,3	4,2		47,6	47,0	44,3	33,8	23,6	10,0									
-	<b>K 300 T</b>	2,2	3	-	3120	-	-	9,8	5,3		51,6	50,0	46,8	41,4	34,8	24,1	16,4								

a) ~ Monofase 220 V

b) ~ Trifase 220/380 V

TIPO TYPE		Potenza nominale Nominal power		Potenza assorbita Input power [W]		Condensatore Capacitor 450 V max	Corrente assorbita Input current [A]			Portata - Capacity															
Monofase Single-phase	Trifase Three-phase	kW	HP	a	b	[μF]	1~220V	3~220V	3~380V	Q [m <sup>3</sup> /h]	0	3	6	9	12	15	18	Q [l/s]	0	50	100	150	200	250	300
a	b									Prevalenza (m C.A.) Total head (m W.C.)															
-	<b>K 400 T</b>	3	4	4530	4530	-	-	14	6,8	H [m]	49,5	48,0	47,0	44,5	42,0	38,7	34								
<b>K 550 M</b>	<b>K 550 T</b>	4	5,5	5400	5700	60	26,2	17	8		57,0	56,0	54,0	51,5	49,0	45	41								

b) ~ Trifase 220/380 V

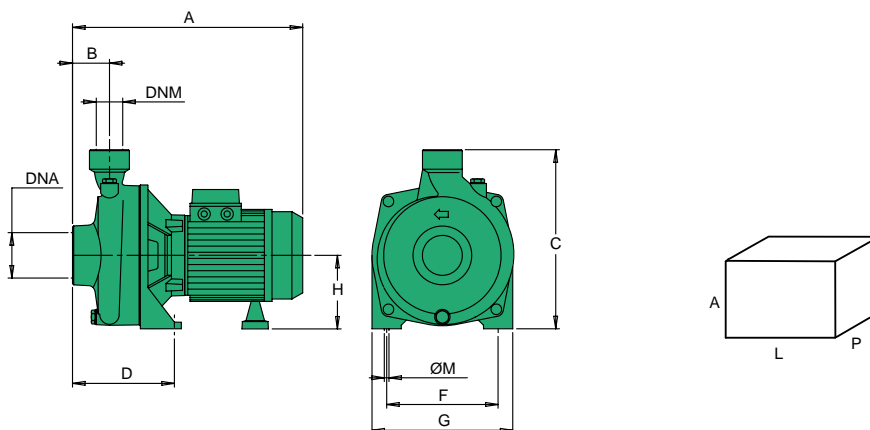

TIPO TYPE	DIMENSIONI [mm] DIMENSIONS [mm]										IMBALLO [mm] PACKING [mm]			PESO WEIGHT [kg]
	A	B	C	D	F	G	Ø	H	DNA	DNM	A	L	P	
<b>K 50</b>	265	45	206	103	124	164	9	85	1"	1"	170	300	250	7,5
<b>K 80</b>	283	45	237	105	140	180	9	97	1"	1"	280	330	200	11,2
<b>K 100</b>	283	45	237	105	140	180	9	97	1"	1"	280	330	200	11,8
<b>K 151</b>	344	47	262	107	149	199	11	110	1" 1/4	1"	320	350	220	20,3
<b>K 201</b>	344	47	262	107	149	199	11	110	1" 1/4	1"	320	350	220	22,8
<b>K 200</b>	373	52	294	30	160	223	11	118	1" 1/4	1"	350	450	260	23,7
<b>K 300</b>	373	52	294	30	160	223	11	118	1" 1/4	1"	350	450	260	25
<b>K 400</b>	442	57	340	93	200	250	14	150	1" 1/2	1" 1/4	380	290	520	44,5
<b>K 550</b>	442	57	340	93	200	250	14	150	1" 1/2	1" 1/4	380	290	520	46,5

min<sup>-1</sup> ~ 2900

min<sup>-1</sup> ~ 3400

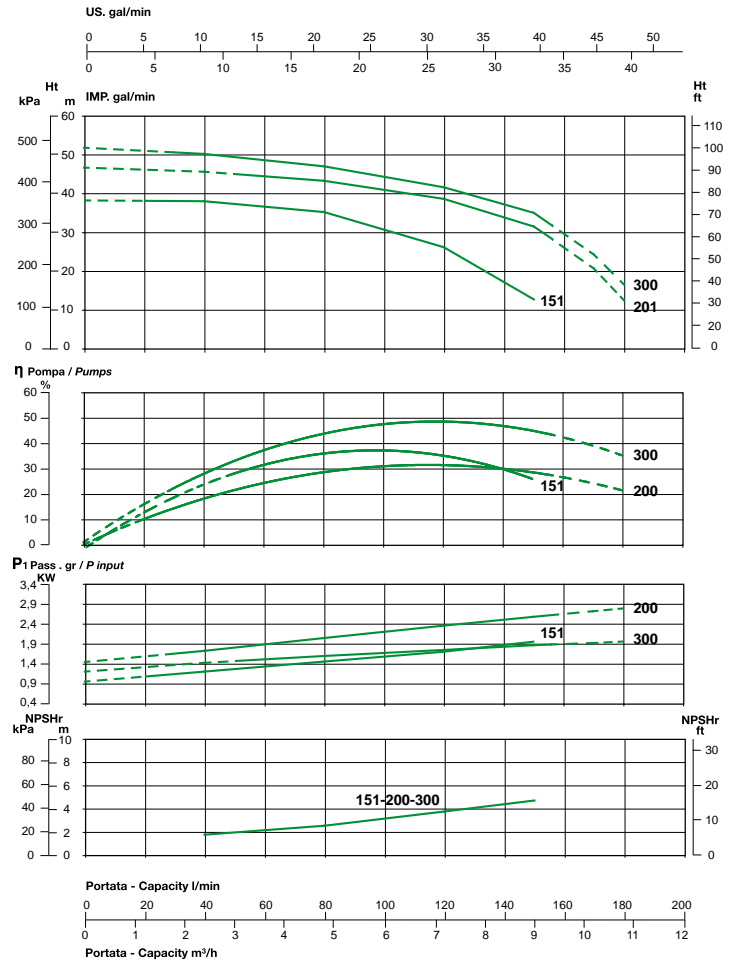
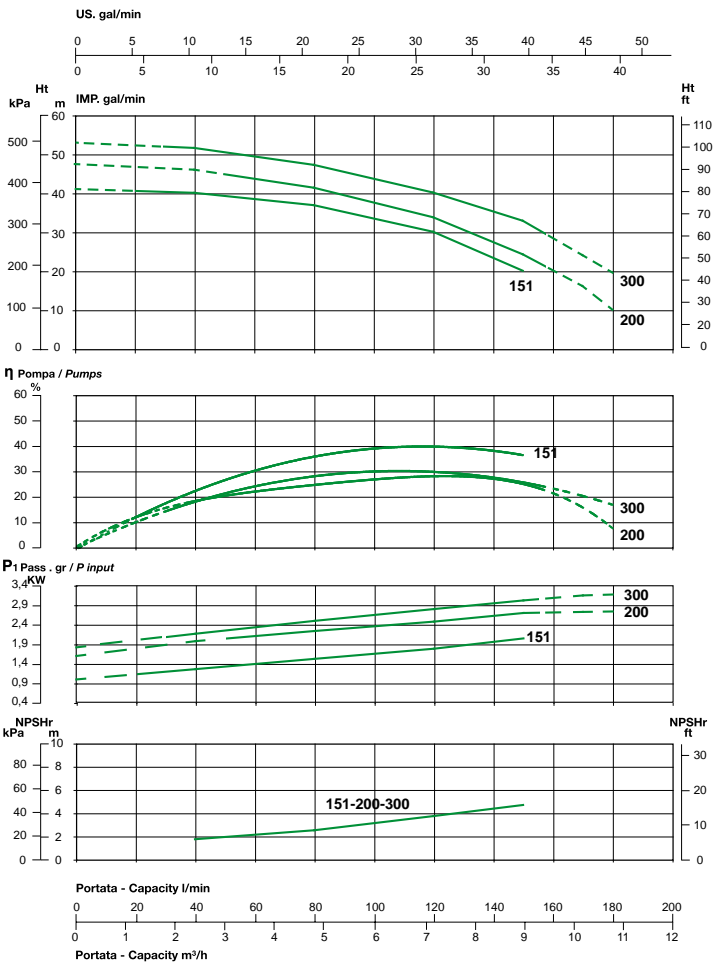
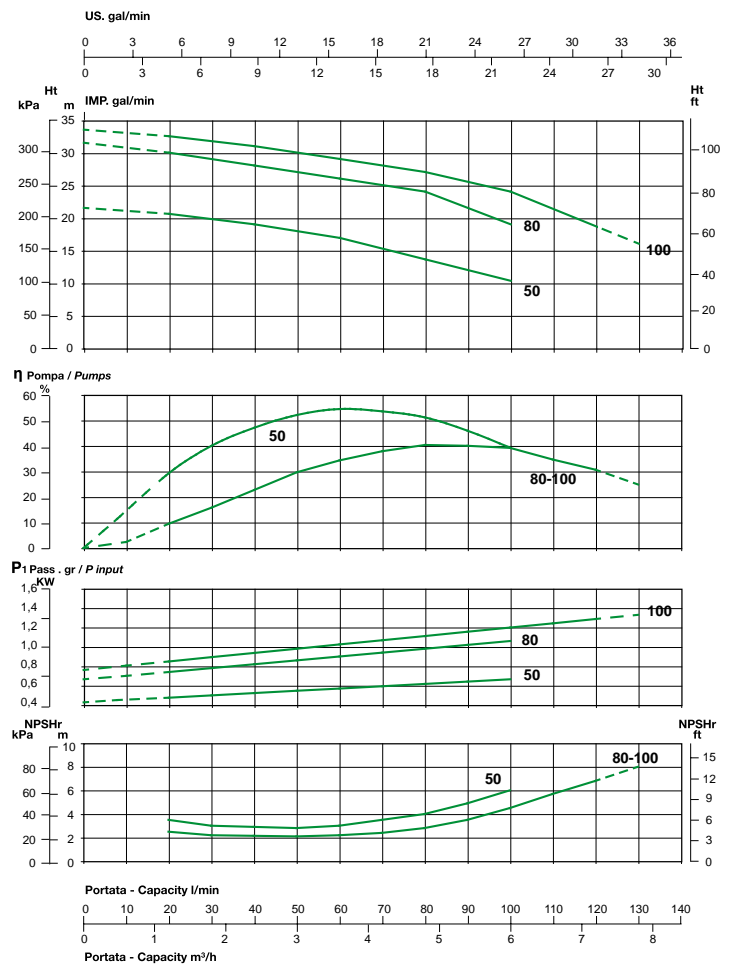
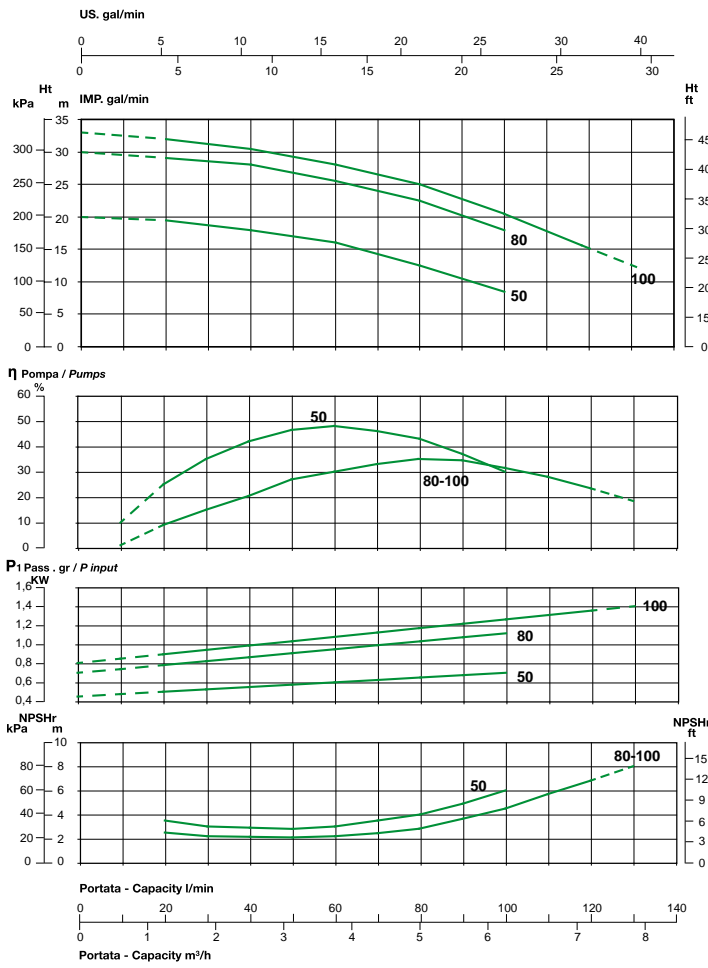

$\text{min}^{-1} \sim 2900$

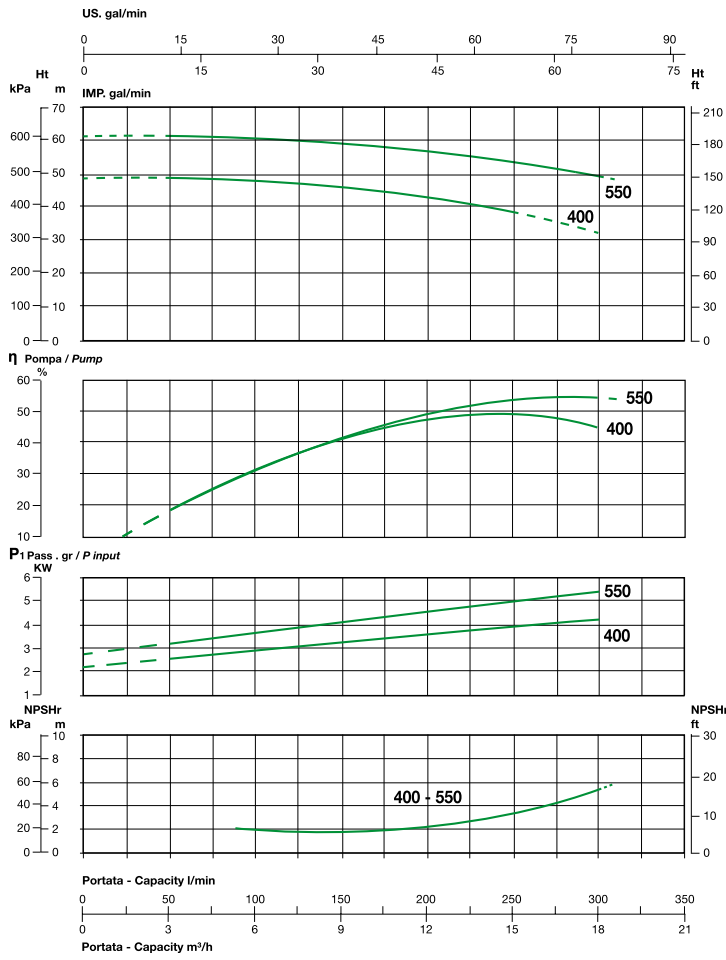

$\text{min}^{-1} \sim 3400$

