

DV 25-30-40

sommersibili per acque reflue



APPLICATIONS



NOMENCLATURA PARTI DI RICAMBIO SPARE PARTS LIST NOMENCLATURE PIÈCES DE RECHANGE NOMENCLATURA REPUESTOS

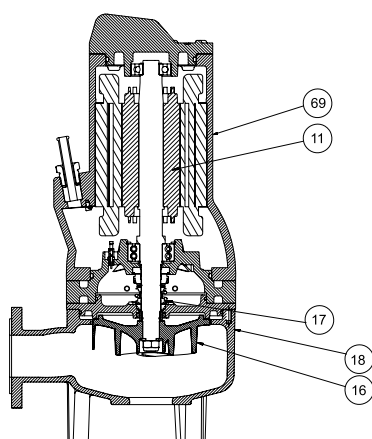

Albero con rotore – Pump shaft + rotor Arbre + rotor – Eje rotor	11
Girante – Impeller Turbine – Impulsor	16
Tenuta meccanica – Mechanical seal Garniture mécanique – Cierre mecánico	17
Corpo pompa – Pump body Corp de pompe – Cuerpo bomba	18
Manico – Handle Poignée – Manejar	57
Camicia – Cover Chemise – Camisa	69

ELETTROPOMPE SOMMERGIBILI PER ACQUE REFLUE 3"

Le elettropompe sommergibili con girante a vortice non intasabile della serie DV sono state progettate per pompare liquidi luridi, chimicamente non aggressivi per i materiali della pompa, anche con corpi solidi in sospensione con un massimo: Ø 63mm per DV25, Ø 78mm per DV30, Ø 88mm per DV40. Temperatura max. 35 °C (CEI EN 60335-2-41).

CARATTERISTICHE COSTRUTTIVE

Corpo motore e pompa	Ghisa meccanica G25 con trattamento anticorrosione
Girante	A vortice in ghisa meccanica G25 con trattamento anticorrosione
Albero pompa	Acciaio inox AISI 420
Tenuta meccanica lato pompa	Carburo di silicio-carburo di silicio
Tenuta meccanica lato motore	Allumina - carbone
Controflange filettate	Acciaio zincato complete di guarnizioni in EPDM
Cavo di alimentazione	10 m in neoprene H07RN-F.

MOTORE

- Motore ad induzione a due poli o quattro poli, riavvolgibile
- Protezione IP68
- Isolamento classe F
- Alimentazione trifase ad avviamento diretto con protezione obbligatoria a cura dell'utente.
- Servizio continuo entro i campi di lavoro previsti e se completamente immersa.

A RICHIESTA:

- Sonda per rilevamento di eventuali infiltrazioni di liquido nella camera olio.
- Cavo elettrico di alimentazione per avviamento stella triangolo.
- Piede d'accoppiamento e dispositivo di discesa rapida mediante tubi di guida.

ÉLECTROPOMPES SUBMERSIBLES POUR EAUX USÉES

Les électropompes submersibles à roue vortex non obturable de la série DV ont été conçues pour pomper des liquides sales, chimiquement non agressifs pour les matériaux de la pompe, même avec des corps solides en suspension avec un maximum: Ø 63mm pour DV25, Ø 78mm pour DV30, Ø 88mm pour les DV40. Température max. 35 °C (CEI EN 60335-2-41).

CARACTERISTIQUES DE CONSTRUCTION

Carcasse moteur et de pompe	En fonte G25 avec traitement anti-corrosion
Turbine	Vortex en fonte G25 avec traitement anti-corrosion
Abre de pompe	Acier inox AISI 420
Garniture mécanique partie pompe	Carbure de silicium-carbure de silicium
Garniture mécanique partie moteur	Alumine - charbon
Contre brides filetées	Acier galvanisé avec joints en EPDM
Câble d'alimentation	10 mt H07RN-F.

MOTOR

- Moteur à induction à deux pôles rebobinable,
- protection IP68
- classe d'isolation F
- Pour les modèles triphasés, la protection est à la charge de l'utilisateur. A recommandé l'équipement conformément à la réglementation
- service S1 (s'il est complètement immergé)

SUR DEMANDE:

- La sonde de détection de fuite de liquide dans la chambre à huile.
- Câble d'alimentation électrique pour démarreur étoile-triangle.
- Dispositif d'accouplement des pieds et raccord rapide.

SUBMERSIBLE ELECTRIC WASTEWATER PUMPS 3"

The submersible electric wastewater pumps with non-clog vortex impeller of the series DV have been designed to pump waste water, chemically not aggressive for the pumps' material. also with suspended solids with a max.: Ø 63mm for DV25, Ø 78mm for DV30, Ø 88 for DV40. Temperature not higher than 35 °C (CEI EN 60335-2-41).

TECHNICAL FEATURES

Motor and pump body	Cast iron G25 with anti-corrosive coating
Impeller	Vortex impeller in cast iron G25 with anti-corrosive coating
Pump shaft	Stainless steel AISI 420
Mechanical seal pump side	Silicon carbide-silicon carbide
Mechanical seal motor side	Alumina - carbon
Threaded counter flange	Galvanized steel complete with EPDM gaskets
Feeding cable	10 m in Neoprene H07RN-F.

MOTOR

- Two or four poles induction rewindable motor
- Protection IP 68
- Class F insulation
- Compulsory three-phase feeding protection with DOL starting is to be supplied by the user.
- Continuous duty within the range areas and if completely submerged.

ON REQUEST:

- Seal probe to detect water ingress into oil chamber.
- Electric power cable for star-delta starting.
- Coupling foot and rapid guide rails device.

ELECTROBOMBAS SUMERGIBLES PARA AGUAS RESIDUALES

Las electrobombas sumergibles con impulsor de torbellino no atascable de la serie DV han sido proyectadas para bombear líquidos fecales, químicamente no agresivos para los materiales de la bomba, incluso con cuerpos sólidos en suspensión con un máximo: Ø 63mm para DV25, Ø 78mm para DV30, Ø 88 para la DV40. Temperatura max. 35 °C (CEI EN 60335-2-41).

CARACTERISTICAS DE CONSTRUCCIÓN

Cuerpo de motor y de bombe	Fundición gris G25 con tratamiento contra-corrosión;
Rodete	Vortex Fundición gris G25 con tratamiento contra-corrosión
Eje de la bomba	Acero Inox AISI 420
Cierre mecánico lado bombas	Carburo de silicio-silicio
Cierre mecánico lado motor	Alumina - carbon
Contra bridas roscadas	Acero galvanizado con juntas de EPDM
Cable de alimentación	10 mt H07RN-F

MOTOR

- Motor a induction de dos poles rebobinables
- Protección IP68
- Aislamiento de clase F
- Para los modelos trifásicos de la protección se encarga el usuario. y el equipo recomendado de acuerdo con las normas
- Funcionamiento S1 (si es completamente sumergida)

BAJO DEMANDA:

- Sonda para la detección de cualquier fuga de líquido en la cámara de aceite.
- Cable eléctrico de alimentación para la estrella-triángulo
- Pie de acoplamiento y de elevación rápida.

DV 25 - 50 Hz

TIPO TYPE Trifase Three-phase	Potenza nominale Nominal power		Potenza assorbita Input power [W]	Giri min RPM	Corrente assorbita Input current [A]	Portata - Capacity															
	kW	HP				Prevalenza (m C.A.) Total head (m W.C.)															
						0	4	9	18	30	42	48	54	60	76	86					
DV 25/251T4	1,85	2,5	2500	1450	4,4	9,9	9,5	8,7	7,7	5,6	2,7										
DV 25/251T2	1,85	2,5	2600	2850	4,4	14,9	14,1	13,1	10,5	7	3,5										
DV 25/301T2	2,2	3	3310	2850	5,4	17,4	16,3	14,8	12,7	9,3	5,8	3,8									
DV 25/401T2	3	4	4100	2850	6,8	19,1	18	16,5	14	10,6	7	5	2,8								
DV 25/551T2	4	5,5	5600	2850	10	24	22,8	22,2	20,3	18,5	15,5	14	12,5	10,8	7	2,2					

DV 30 - 50 Hz

TIPO TYPE Trifase Three-phase	Potenza nominale Nominal power		Potenza assorbita Input power [W]	Giri min RPM	Corrente assorbita Input current [A]	Portata - Capacity															
	kW	HP				Prevalenza (m C.A.) Total head (m W.C.)															
						0	9	20	30	40	48	60	78	84	90	96					
DV 30/301T4	2,2	3	2900	1450	5,2	11,6	11,5	10,7	8,9	7,8	6,1	3,5	2,1								
DV 30/301T2	2,2	3	2800	2850	5,4	14,8	13,6	11,1	9	6,5	4,7	2,3									
DV 30/401T2	3	4	4200	2850	6,8	17,5	16	13,7	10,7	9	6,7	3,5									
DV 30/551T2	4	5,5	5400	2850	6,5	20,2	18,6	16,8	15	13	11,4	9	5,2	4,3							
DV 30/751T2	5,5	7,5	6400	2850	12,5	26,1	24,5	22,6	20,5	18,4	16,5	13,8	9	8	6,5	5,7					
DV 30/1001T2	7,5	10	9000	2850	16,8	31	29,4	27,5	25,3	23,3	21,4	18,7	14	13	11,5	9,1					

DV 40 - 50 Hz

TIPO TYPE Trifase Three-phase	Potenza nominale Nominal power		Potenza assorbita Input power [W]	Giri min RPM	Corrente assorbita Input current [A]	Portata - Capacity															
	kW	HP				Prevalenza (m C.A.) Total head (m W.C.)															
						0	9	20	30	40	48	60	78	84	90	96					
DV 40/751T2	5,5	7,5	6400	2850	12,5	25,1	23,8	22,2	20,5	18,5	16,5	14,2	9,9	9,3	8,3	7,9					
DV 40/1001T2	7,5	10	9000	2850	16,8	29,8	28,5	26,8	25,0	22,9	21	18,4	13,6	12,5	11	10					

b) ~ Trifase 400 V

DV 25 - 60 Hz

TIPO TYPE Trifase Three-phase	Potenza nominale Nominal power		Potenza assorbita Input power [W]	Giri min RPM	Corrente assorbita Input current [A]	Portata - Capacity											
	kW	HP				Prevalenza (m C.A.) Total head (m W.C.)											
						0	4,0	9,0	18	30,0	42,0	48,0	54,0	60	76,0	86,0	
						Q [m ³ /h]	0	4,0	9,0	18	30,0	42,0	48,0	54,0	60	76,0	86,0
						Q [l/s]	0	66	150	300	500	700	800	900	1000	1266	1434
							Prevalenza (m C.A.) Total head (m W.C.)										
							3~400 V										
DV 25/251T4	1,85	2,5	2500	1750	4,4	H [m]	9,9	9,5	8,7	7,7	5,6	2,7					
DV 25/251T2	1,85	2,5	2600	3400	4,4		14,9	14,1	13,1	10,5	7	3,5					
DV 25/301T2	2,2	3	3310	3400	5,4		17,4	16,3	14,8	12,7	9,3	5,8	3,8				
DV 25/401T2	3	4	4100	3400	6,8		19,1	18,0	16,5	14	10,6	7	5	2,8			
DV 25/551T2	4	5,5	5600	3400	10		24,0	22,8	22,2	20,3	19,5	15,5	14	12,5	10,8	7	2,2

DV 30 - 60 Hz

TIPO TYPE Trifase Three-phase	Potenza nominale Nominal power		Potenza assorbita Input power [W]	Giri min RPM	Corrente assorbita Input current [A]	Portata - Capacity											
	kW	HP				Prevalenza (m C.A.) Total head (m W.C.)											
						0	9	20	30	40	48	60	78	84	90	96	
						Q [m ³ /h]	0	9	20	30	40	48	60	78	84	90	96
						Q [l/s]	0	150	333	500	666	800	1000	1300	1400	1500	1600
							Prevalenza (m C.A.) Total head (m W.C.)										
							3~400 V										
DV 30/301T4	2,2	3	2900	1750	5,2	H [m]	11,6	11,5	10,7	8,9	7,8	6,1	3,5	2,1			
DV 30/301T2	2,2	3	2800	3400	5,4		14,8	13,6	11,1	8	6,5	4,7	2,3				
DV 30/401T2	3	4	4200	3400	6,8		17,5	16	13,7	10,7	9	6,7	3,5				
DV 30/551T2	4	5,5	5400	3400	6,5		20,2	18,6	16,8	15	13	11,4	9	5,2	4,3		
DV 30/751T2	5,5	7,5	6400	3400	12,5		26,1	24,5	22,6	16,5	18,4	16,5	13,8	9	8	6,5	5,7
DV 30/1001T2	7,5	10	9000	3400	16,8	31	29,4	27,5	25,3	23,3	21,4	18,7	14	13	11,5	9,1	

DV 40 - 60 Hz

TIPO TYPE Trifase Three-phase	Potenza nominale Nominal power		Potenza assorbita Input power [W]	Giri min RPM	Corrente assorbita Input current [A]	Portata - Capacity											
	kW	HP				Prevalenza (m C.A.) Total head (m W.C.)											
						0	9	20	30	40	48	60	78	84	90	96	
						Q [m ³ /h]	0	9	20	30	40	48	60	78	84	90	96
						Q [l/s]	0	150	333	500	666	800	1000	1300	1400	1500	1600
							Prevalenza (m C.A.) Total head (m W.C.)										
							3~400 V										
DV 40/751T2	5,5	7,5	6400	3400	12,5	H [m]	25,1	23,8	22,2	20,5	18,5	16,5	14,2	9,9	9,3	8,3	7,9
DV 40/1001T2	7,5	10	9000	3400	16,8		29,8	28,5	26,8	25	22,9	21	18,4	13,6	12,5	11	10

b) ~ Trifase 400 V

min⁻¹ ~ 2900

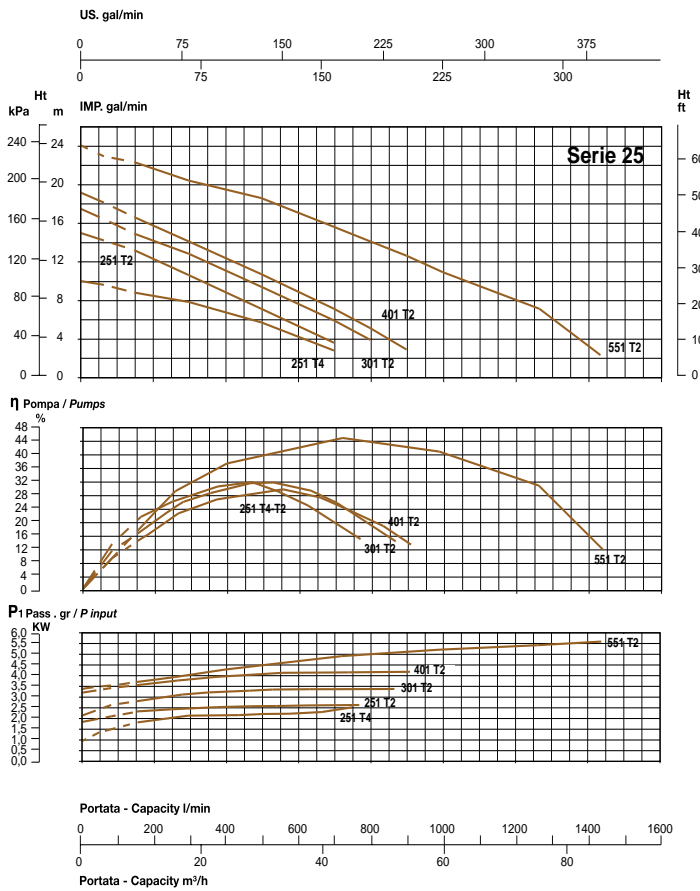

min⁻¹ ~ 3400

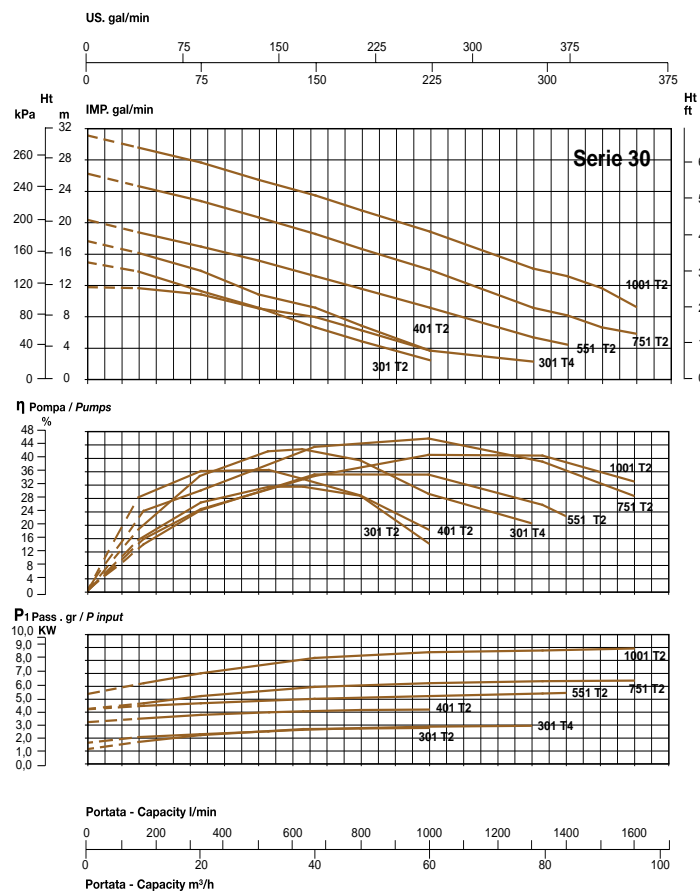
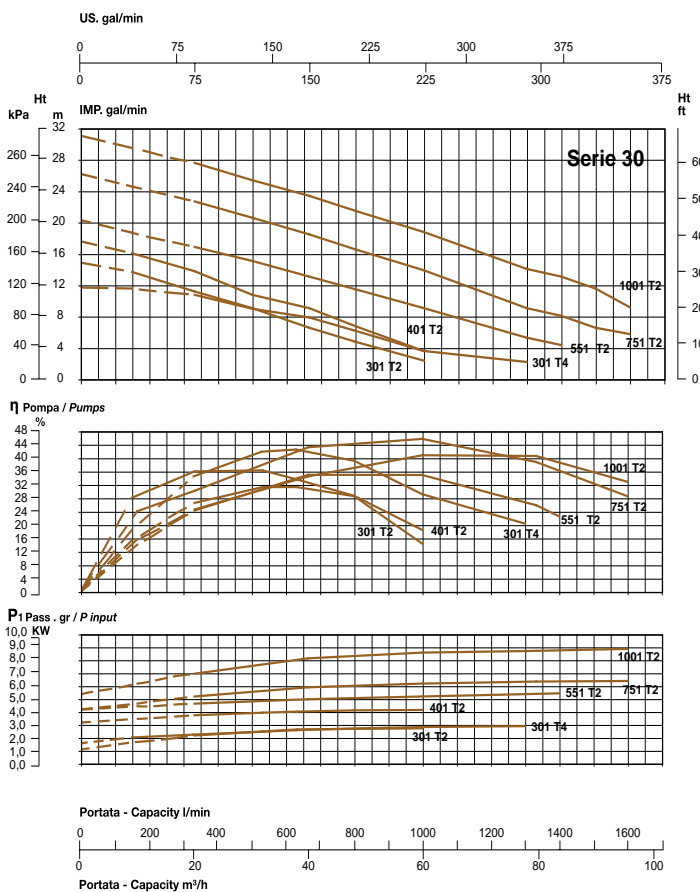
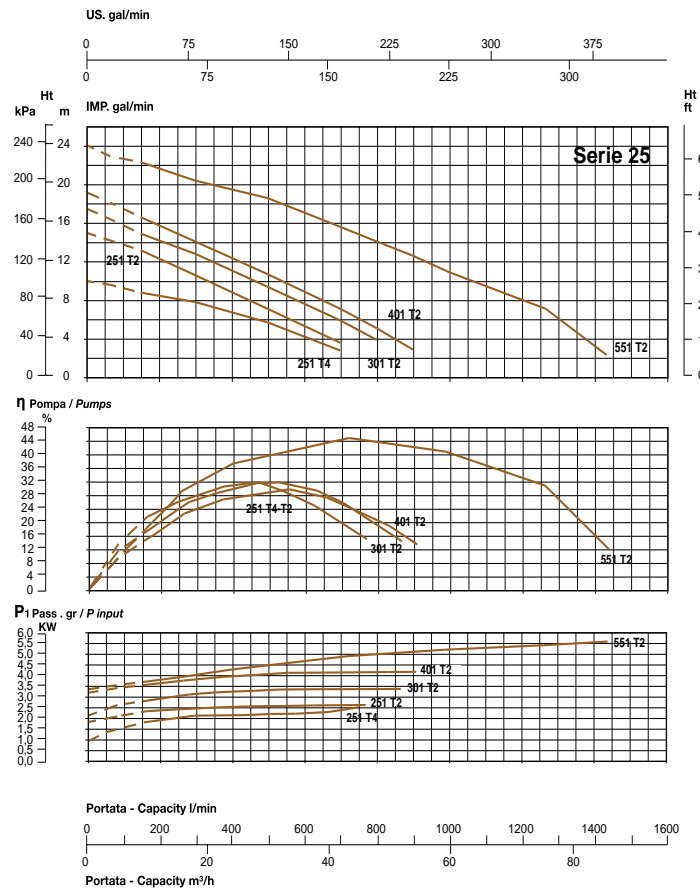

min⁻¹ ~ 2900

min⁻¹ ~ 3400

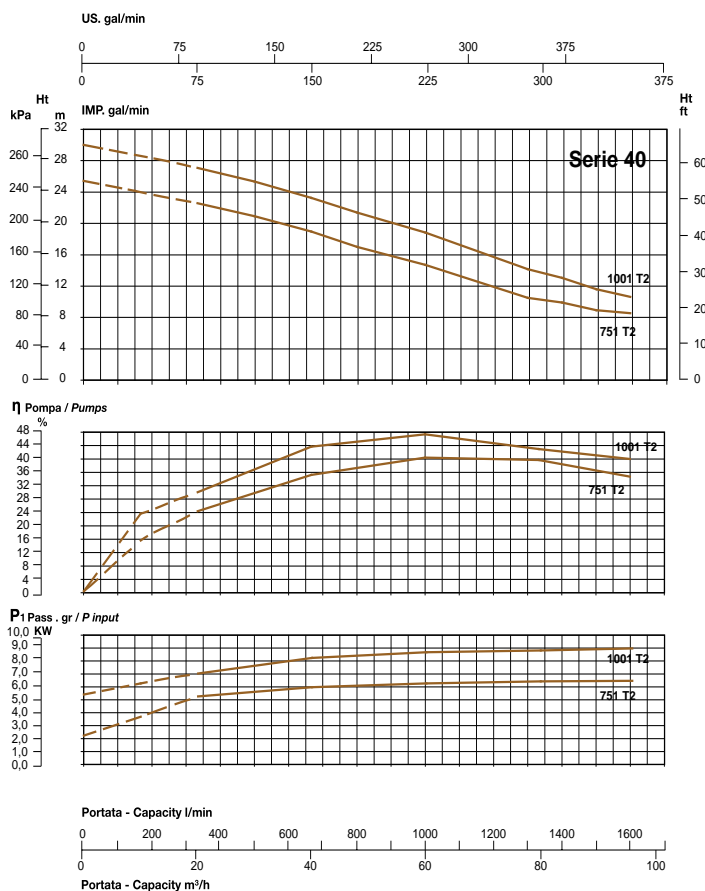
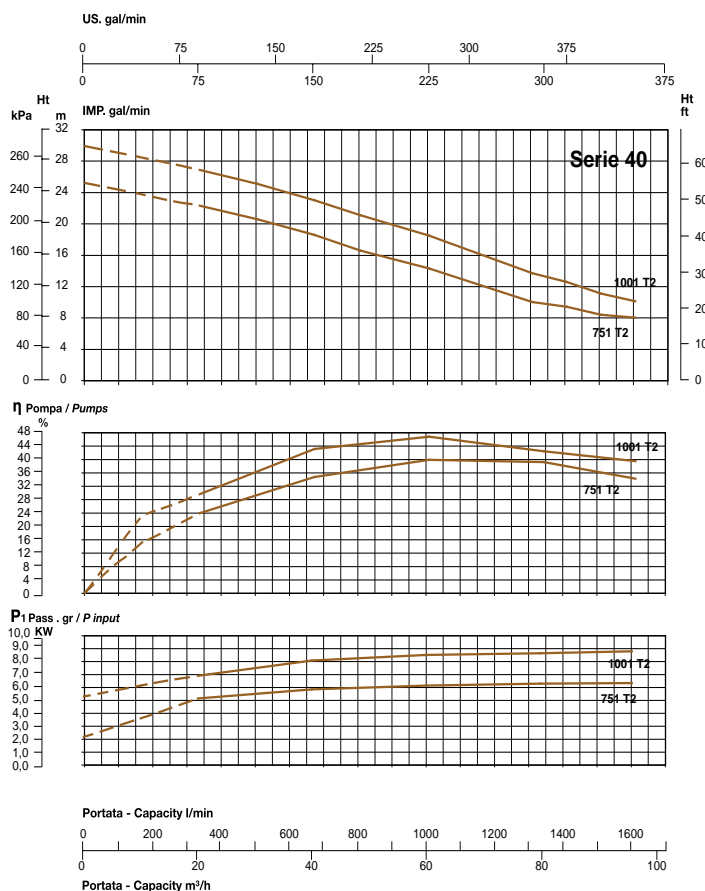

- Dal 3.7 kW sovradimensionamento dell'albero e dei cuscinetti (cuscinetto inferiore a doppia sfera di corona)
- From 3.7 kW version shaft and bearing (lower bearing double row angular contact ball type)
- A partir de puissance de 3.7 kW arbre moteur et roulements robustes (roulement infeieur a double billes couronnes)
- Desde sobredimensionamiento 3.7 kW eje y cojinetes (Baja teniendo doble esfera de coronas)
- Miglior efficienza idraulica Nuovo sistema di giranti vortex che garantisce una minor instabilità
- Increased Hydraulic efficiency New system of vortex impellers designed to prevent clogging
- Meilleur rendement hydraulique Nouveau système hydraulique qui garantit une colmatage inférieure
- Mejor eficiencia hydraulica Sistema nuevo del vòrtice rodete asegurando así un paralización menor

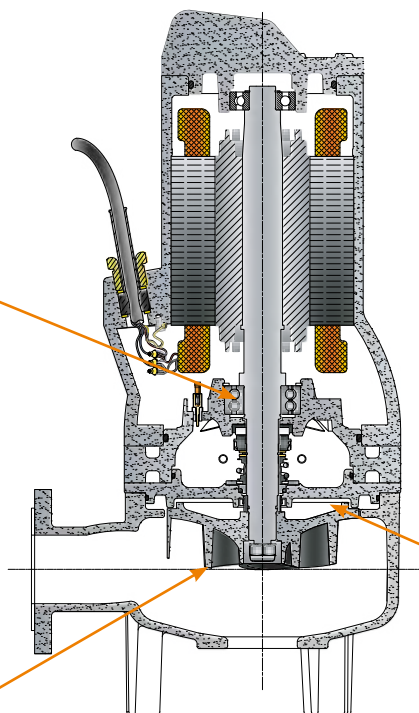

- Sistema di protezione della tenuta meccanica inferiore migliorata con anello di tenuta radiale
- Improved protection of the lower mechanical seal by means of radial seal ring
- Système de protection de la garniture mécanique inférieure améliorée avec bague d'étanchéité radiale
- Protector seal automated inferior mejorado mecánico con el anillo de junta

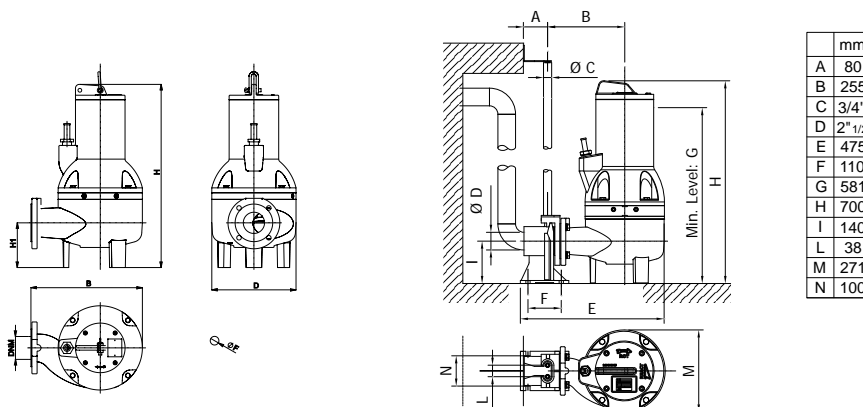

TIPO TYPE	DIMENSIONI [mm] DIMENSIONS [mm]						IMBALLO [mm] PACKING [mm]			PESO WEIGHT [kg]
	B	D	F	H	H1	DNM	A	L	P	
DV 25/251T4	344	260	63	565	138	2" 1/2	670	280	380	58,3
DV 25/251T2	344	260	63	565	138	2" 1/2	670	280	380	57
DV 25/301T2	344	260	63	565	138	2" 1/2	670	280	380	61,7
DV 25/401T2	344	260	63	565	138	2" 1/2	670	280	380	62,1
DV 25/551T2	350	262	63	668	138	2" 1/2	670	280	380	89,5

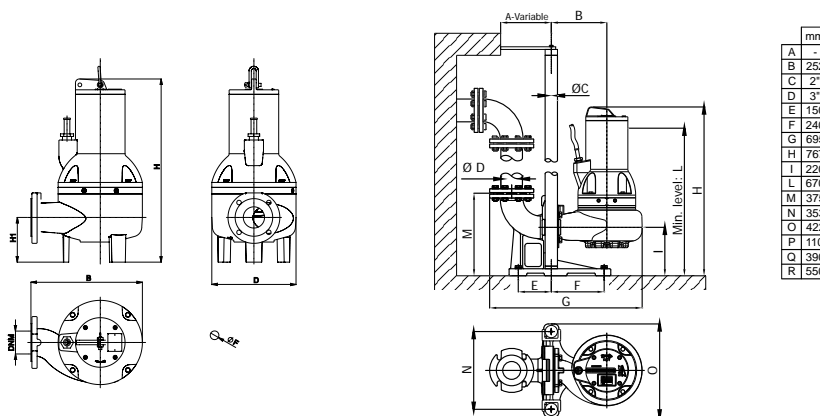

TIPO TYPE	DIMENSIONI [mm] DIMENSIONS [mm]						IMBALLO [mm] PACKING [mm]			PESO WEIGHT [kg]
	B	D	F	H	H1	DNM	A	L	P	
DV 30/301T4	401	322	78	650	92	3"	800	350	430	78,3
DV 30/301T2	401	322	78	650	92	3"	800	350	430	71
DV 30/401T2	401	322	78	650	92	3"	800	350	430	72,3
DV 30/551T2	401	322	78	750	92	3"	800	350	430	104,3
DV 30/751T2	401	322	78	750	92	3"	800	350	430	111,4
DV 30/1001T2	401	322	78	750	92	3"	800	350	430	111,3

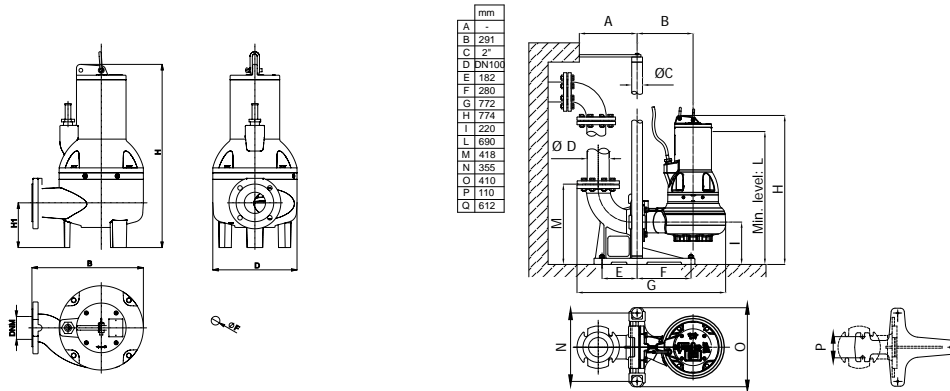

TIPO TYPE	DIMENSIONI [mm] DIMENSIONS [mm]						IMBALLO [mm] PACKING [mm]			PESO WEIGHT [kg]
	B	D	F	H	H1	DNM	A	L	P	
DV 40/751T2	450	340	88	760	100	4"	800	500	350	110
DV 40/1001T2	450	340	88	760	100	4"	800	500	350	112