

CN

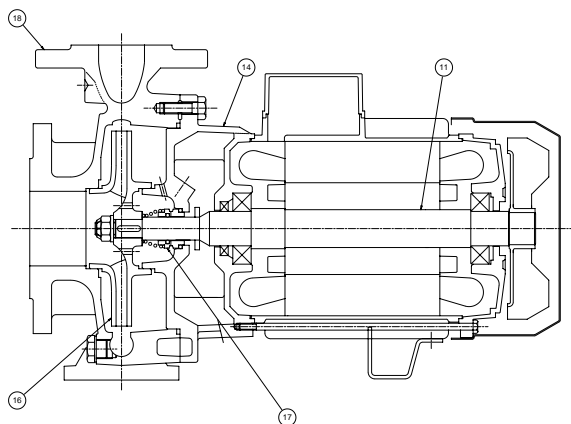

CN - CNG - ING - BSN

- Albero con rotore - Pump shaft + rotor 11
 Arbore + rotor - Eje rotor
- Supporto mandata - Outlet bracket 14
 Supporte envoyée - Soporte entrega
- Girante - Impeller 16
 Turbine - Impulsor
- Tenuta meccanica - Mechanical seal 17
 Garniture mécanique - Cierre mecánico
- Corpo pompa - Pump body 18
 Corp de pompe - Cuerpo bomba
- Giunto - Coupling 34
 Manchon - Acoplamiento

CNG

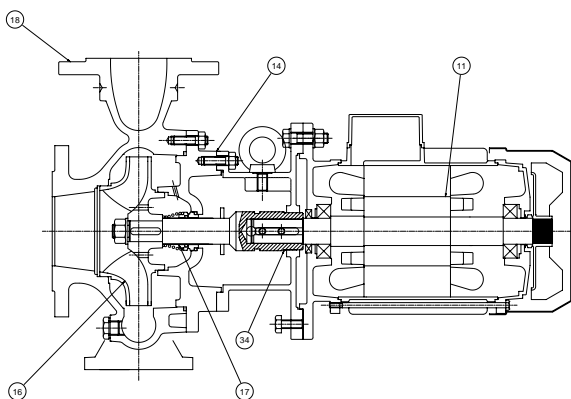

APPLICATIONS



ING

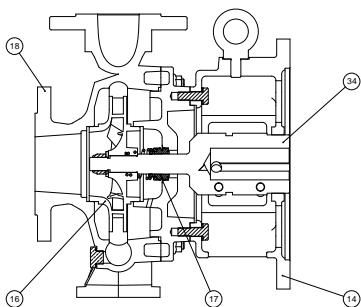

BSN

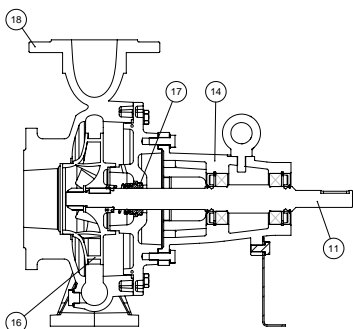

CN



CNG



ING



BSN



POMPE CENTRIFUGHE NORMALIZZATE

Le elettropompe centrifughe normalizzate, costruite in accordo con le normative UNI EN 733 (DIN 24255), sono disponibili in versione monoblocco serie CN, in versione giunto rigido serie CNG e ING, e in versione giunto flessibile BSN. Sono state progettate per il pompaggio di liquidi puliti, senza parti abrasive, senza corpi solidi in sospensione, non esplosivi o aggressivi per i materiali della pompa.

- Temperatura del liquido fino a 35 °C per uso domestico (CEI EN 60335-2-41) o 90 °C per altri usi e temperatura ambiente fino a 40 °C
- Portate fino a 240 m³/h
- Prevalenze fino a 100 m.

CARATTERISTICHE COSTRUTTIVE

Corpo pompa e supporto motore	Ghisa G20 con trattamento anticorrosione
Supporto motore	Ghisa G20 con trattamento anticorrosione
Bocche aspirazione/mandata	A norme DIN 2532
Girante	Ghisa G20 con trattamento in cataforesi
Controflange filettate	Acciaio zincato complete di guarnizioni in EPDM
Albero pompa	Acciaio inox AISI 304
Tenuta meccanica	Carbone - Ceramica

MOTORE

I motori di comando sono del tipo asincrono a gabbia di scoiattolo chiusi, a ventilazione esterna.

- Motoprotettore incorporato e condensatore permanentemente inserito per i tipi monofasi
- La protezione del motore nella versione trifase è a cura del cliente e si raccomandano apparecchiature in accordo con le norme vigenti
- Forme costruttive serie CNG IM B3/B5
- Isolamento classe F
- Servizio S1
- Grado di protezione IP 54
- Protezione morsettiera IP 54
- Versione 4 Poli disponibile per CNG e BSN.

POMPES CENTRIFUGES NORMALISÉES

Les Pompes centrifuges normalisées, construites en conformité avec la norme UNI EN 733 (DIN 24255), sont disponibles en série monoblocs CN, version de couplage rigide série CNG et ING, et la version accouplement flexible BSN. Elles ont été conçues pour le pompage de liquides propres, sans parties abrasives, sans corps liquides en suspension, non explosifs ou agressifs pour les matériaux de la pompe.

- Température du liquide jusqu'à 35 °C pour utilisation domestique (CEI EN 60335-2-41) o 90 °C pour d'autres utilisations et température ambiante jusqu'à 40 °C
- Plage d'utilisation jusqu'à 240 m³/h
- Hauteur manométrique jusqu'à 100 m.

CARACTERISTIQUES DE CONSTRUCTION

Corps de pompe et lanterne	En fonte G20 avec traitement anti-corrosion
Aspiration/refoulement	norme DIN 2532
Turbine	En fonte G20 avec traitement en cataphorèse
Contre brides filetées	Acier galvanisé avec joints en EPDM
Abre de pompe	Acier inox AISI 304
Garniture mécanique	Carbone - Céramique

MOTOR

Les moteurs sont asynchrones à cage d'écuriel fermés à ventilation extérieure monofásicos.

- Pour le modèles monophasé son avec protection thermique et condensateur connecté en permanence
- Pour les modèles triphasés, la protection est à la charge de l'utilisateur. A recommandé l'équipement conformément à la réglementation
- Forme de bride B3/B5 por série CNG
- A Classe d'isolation F
- service S1
- protection IP54
- Protection IP54 dans le terminal
- Version 4 pôles disponibles pour série CNG et BSN

NORMALIZED CENTRIFUGAL PUMPS

The normalised centrifugal pumps, made in compliance of DIN 24255 (UNI EN 733) standards, are available in monobloc version CN, with stub series CNG and ING, and with flexible coupling series BSN. They have been designed to pump clean liquids, without abrasives and suspended solids, non-explosive or aggressive for the pump's materials.

- Liquid temperature not higher than 35 °C for domestic use (CEI EN 60335-2-41) or 90 °C for other use, while the ambient temperature must not be higher than 40 °C
- Flow rates up to 240 m³/h
- Heads up to 100 m.

TECHNICAL FEATURES

Pump body and motor bracket	Cast iron G20 with anti-corrosive coating
Orifices in/outlet	DIN 2532 standards
Impeller	Cast iron G20 with cathaphoresis treatment
Threaded counter flanges	Galvanized steel complete with EPDM gaskets
Pump shaft	Stainless steel AISI 304
Mechanical seal	Carbon - Ceramics

MOTOR

The control motors are asynchronous, squirrel cage-type, closed, with external ventilation.

- Incorporated motor protection and capacitor always on, for single-phase models
- The motor protection for three-phase models must be installed by the customer. Equipment compliant with current standards should be used
- IM B3/B5 flange for series CNG
- Class of insulation F
- Service S1
- Degree of protection IP 54
- Terminal board protection IP 54
- 4 poles version available for CNG and BSN version.

BOMBAS CENTRÍFUGAS NORMALIZADAS

Las Bombas centrífugas normalizadas, son producidas de acuerdo con la norma UNI EN 733 (DIN 24255), están disponibles en versión mono bloque serie CN, versión de acoplamiento rígido la serie CNG y ING, y la versión de acoplamiento flexible serie BSN. Han sido proyectadas para bombear líquidos limpios sin partes abrasivas, sin cuerpos sólidos en suspensión, que no sean explosivos ni agresivos para los materiales de la bomba.

- Temperatura del líquido hasta 35 °C para uso doméstico (CEI EN 60335-2-41) o 90 °C para otros usos y temperatura ambiente hasta 40 °C
- Caudal hasta 240 m³/h
- Alturas hasta 100 m.

CARACTERÍSTICAS DE CONSTRUCCIÓN

Cuerpo de bomba y soporte	Fundición gris G20 con tratamiento contra-corrosión
Bocas de entrada y salida	Normalizadas DIN 2532
Rodete	Fundición gris G20 con tratamiento en cataforesis
Contra bridas roscadas	Acero galvanizado con juntas de EPDM
Eje de la bomba	Acero Inox AISI304
Cierre mecánico	Cerámica - Grafito

MOTOR

Los motores de accionamiento son asincrono de jaula de ardilla cerrados, ventilados externamente.

- Para los modelos monofásicos, protección térmica y condensador incorporado
- Para los modelos trifásicos de la protección se encarga el usuario. y el equipo recomendado de acuerdo con las normas
- Aislamiento de Clase F
- Funcionamiento S1
- Protección IP54
- Serie CNG embridado para forma IM B3/B5
- Protección IP54 para el terminal
- Versión 4 poles disponible para CNG y BSN

2 POLES 50Hz

MOTOR TYPE MOTOR TYPE		IEC SIZE	INPUT CURRENT A SINGLE-PHASE			Noise Lpa/dB	MOTOR 230V - 50Hz				
kW	HP	MEC	230V			70	min ⁻¹	ls/lm	Cosfi	Nm	Ts/Tn
1,1	1,5	80	7,50	-	-	70	2830	6,78	0,94	3,70	3,49
1,5	2,0	90	9,30	-	-	70	2835	7,44	0,90	5,10	3,08
2,2	3,0	100	12,80	-	-	70	2795	9,36	0,98	7,50	3,98
3,0	4,0	100	18,20	-	-	70	2800	9,89	0,95	2,00	4,07

MOTOR TYPE MOTOR TYPE		IEC SIZE	INPUT CURRENT A THREE-PHASE			Noise Lpa/dB	MOTOR 400V - 50Hz				
kW	HP	MEC	230V	400V	690V	70	min ⁻¹	ls/lm	Cosfi	Nm	Ts/Tn
1,1	1,5	80	4,6	2,7	-	70	2875	6,78	0,77	3,65	3,49
1,5	2	90	5,3	3	-	70	2885	7,44	0,85	4,97	3,08
2,2	3	90	8,1	4,7	-	70	2890	8,3	0,79	7,3	3,72
3	4	100	10	5,8	-	70	2910	9,36	0,85	9,84	3,98
4	5,5	112	16	7,6	-	71	2890	8,62	0,87	13,2	3,5
5,5	7,5	132	-	10,7	6,2	71	2935	9,82	0,83	17,9	3,47
7,5	10	132	-	13,9	8	71	2925	9,52	0,87	24,5	3,24
9,2	12,5	132	-	17	9,3	71	2920	8,72	0,88	28,6	2,14
11	15	160	-	20	11,5	73	2940	7,59	0,89	35,7	2,11
15	20	160	-	26,3	15,3	78	2945	8,23	0,89	48,6	2,37
18,5	25	160	-	33	20	80	2955	9,25	0,86	59,8	2,62
22	30	180	-	41,7	24,1	80	2930	7,1	0,84	72	2,5
30	40	200	-	54	31,3	80	2950	6,8	0,87	97	2,4
37	50	200	-	65	37,5	80	2950	7,2	0,88	120	2,5
45	60	200	-	80	46	84	2960	6,7	0,88	145	2,4
55	75	250	-	99	57	84	2955	6,7	0,87	178	2,4
75	100	280	-	133	77	84	2960	6,8	0,87	242	2,3

4 POLI 50Hz

MOTOR TYPE MOTOR TYPE		IEC SIZE	INPUT CURRENT A THREE-PHASE		Noise Lpa/dB	MOTOR 400V - 50Hz					
kW	HP	MEC	230V	400V	70	min ⁻¹	la/lm	Cosfi	Nm	Ts/Tn	
0,55	0,75	80 A	-	2,8	1,6	70	1400	3,6	0,72	3,8	2,5
0,75	1	80 B	-	3,7	2,1	70	1410	4,4	0,72	5,1	2,3
1,1	1,5	90 S	-	4,7	2,7	70	1400	5,2	0,78	7,5	2,4
1,5	2	90 L	-	6,3	3,6	70	1400	5,7	0,78	10,2	2,6
2,2	3	100 LA	-	9,4	5,4	70	1435	5,3	0,74	14,6	2,4
3	4	100 LB	-	11,8	6,8	70	1425	4,6	0,78	20,1	2,3
4	5,5	112 M	-	14,8	8,5	70	1430	6,3	0,82	26,7	2
5,5	7,5	132 S	-	19,7	11,3	70	1430	5,8	0,82	36,7	2,7
7,5	10	132 MA	-	26,6	15,3	70	1440	6,8	0,83	49,7	2,7
9,2	12,5	132 MB	-	30,8	17,7	70	1440	8	0,86	61	3,2

2 POLES 60Hz

MOTOR TYPE MOTOR TYPE		IEC SIZE	INPUT CURRENT A SINGLE-PHASE		Noise Lpa/dB	MOTOR 220V - 60Hz				
kW	HP	MEC	220V		70	min ⁻¹	ls/lm	Cosfi	Nm	Ts/Tn
1,10	1,50	80	8,00	-	70	3420	6,78	0,94	3,70	3,49
1,50	2,00	90	9,80	-	70	3435	7,44	0,90	5,10	3,08
2,20	3,00	100	13,40	-	70	3480	9,36	0,98	7,50	3,98
3,0	4,0	100	18,20	-	70	3400	9,89	0,95	2,00	4,07

MOTOR TYPE MOTOR TYPE		IEC SIZE	INPUT CURRENT A THREE-PHASE		Noise Lpa/dB	MOTOR 380V - 60Hz				
kW	HP	MEC	220V	380V	70	min ⁻¹	ls/lm	Cosfi	Nm	Ts/Tn
1,1	1,5	80	4,2	2,5	70	3420	6,26	0,88	3,07	2,52
1,5	2	90	5,8	3,3	70	3435	5,14	0,89	4,17	1,71
2,2	3	90	7,9	4,6	70	3445	7,23	0,89	6,11	2,79
3	4	100	10,5	6	70	3480	7,1	0,89	8,36	2,96
4	5,5	112	13	7,7	71	3475	7,2	0,93	11,1	2,46
5,5	7,5	132,0	18,3	10,6	71	3465	8,09	0,91	14,9	2,48
7,5	10	132	24	14	71	3505	7,54	0,91	20,4	2,31
9,2	12,5	132	31	18	71	3520	5,9	0,91	26	2,2
11	15	160	35	21	73	3520	6,04	0,92	29,9	1,6
15	20	160	47	27	78	3525	6,5	0,92	40,6	1,77
18,5	25	160	57	33,2	80	3540	7,94	0,91	50	2,2
22	30	180	74	43	80	3516	5,3	0,8	35	1,9
30	40	200	97	56	80	3540	5,1	0,9	45	1,8
37	50	200	116	67	80	3540	5,4	0,9	54	1,9
45	60	200	143	83	84	3552	5	0,9	67	1,8
55	75	250	176	103	84	3546	5	0,9	83	1,8
75	100	280	235	138	84	3556	5,1	0,9	111	1,7

4 POLI 60Hz

MOTOR TYPE MOTOR TYPE		IEC SIZE	INPUT CURRENT A THREE-PHASE		Noise Lpa/dB	MOTOR 380V - 60Hz				
kW	HP	MEC	220V	380V	70	min ⁻¹	la/lm	Cosfi	Nm	Ts/Tn
0,55	0,75	80 A	2,6	1,7	70	1700	3,6	0,76	3,8	/
0,75	1	80 B	3,3	1,9	70	1740	4,5	0,72	4,1	3,4
1,1	1,5	90 S	4,4	2,5	70	1745	8	0,76	6	4
1,5	2	90 L	6,5	3,8	70	1735	8,7	0,73	8,3	3,9
2,2	3	100 LA	9,6	5,6	70	1750	8,4	0,7	12	3,1
3	4	100 LB	11,7	6,8	70	1740	9,4	0,76	16,5	2,8
4	5,5	112 M	14,6	8,5	70	1745	6,7	0,81	21,9	3,2
5,5	7,5	132 S	19,7	11,4	70	1755	8,5	0,84	29,9	2,8
7,5	10	132 MA	25,9	15	70	1750	9,1	0,84	40,9	2,9
9,2	12,5	132 MB	33,5	19,4	70	1745	8,8	0,84	50,3	2,9

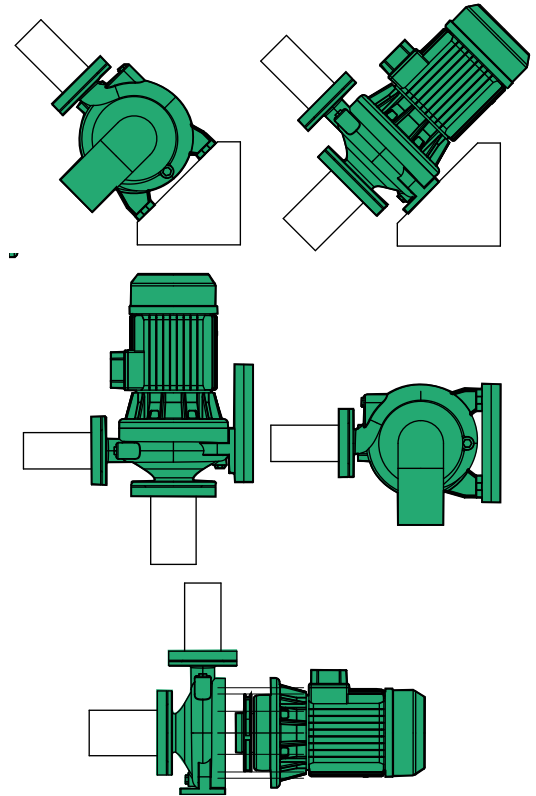

EFFICIENCY CLASSES OF MOTOR - IE CODE 50 Hz

Output kW	IE1 code Standard Efficiency		IE2 code Standard Efficiency		IE3 code Standard Efficiency	
	2 poles	4 poles	2 poles	4 poles	2 poles	4 poles
0,55	-	-	-	-	-	-
0,75	72,10	72,10	77,40	79,60	80,70	82,50
1,10	75,00	75,00	79,60	81,40	82,70	84,10
1,50	77,20	77,20	81,30	82,80	84,20	85,30
2,20	79,70	79,70	83,20	84,30	85,90	86,70
3,00	81,50	81,50	84,60	85,50	87,10	87,70
4,00	83,10	83,10	85,80	86,60	88,10	88,60
5,50	84,70	84,70	87,00	87,70	89,20	89,60
7,50	86,00	86,00	88,10	88,70	90,10	90,40
9,20	-	-	-	-	-	-
11,00	87,60	87,60	89,40	89,80	91,20	91,40
15,00	88,70	88,70	90,30	90,60	91,90	92,10
18,50	89,30	89,30	90,90	91,20	92,40	92,60
22,00	89,90	89,90	91,30	91,60	92,70	93,00
30,00	90,70	90,70	92,00	92,30	93,30	93,60
37,00	91,20	91,20	92,50	92,70	93,70	93,90
45,00	91,70	91,70	92,90	93,10	94,00	94,20
55,00	92,10	92,10	93,20	93,50	94,30	94,60
75,00	92,70	92,70	93,80	94,00	94,70	95,00

EFFICIENCY CLASSES OF MOTOR - IE CODE 60 Hz

Output kW	IE1 code Standard Efficiency		IE2 code Standard Efficiency		IE3 code Standard Efficiency	
	2 poles	4 poles	2 poles	4 poles	2 poles	4 poles
0,55	-	-	-	-	-	-
0,75	77,00	78,00	75,50	82,50	77,00	85,50
1,1	78,50	79,00	82,50	84,00	84,00	86,50
1,5	81,00	81,50	84,00	84,00	85,50	86,50
2,2	81,50	83,00	85,50	87,50	86,50	89,50
3,0	84,50	85,00	87,50	87,50	88,50	89,50
4,0	84,50	85,00	87,50	87,50	88,50	89,50
5,5	86,00	87,00	88,50	89,50	89,50	91,70
7,5	87,50	87,50	89,50	89,50	90,20	91,70
9,2	-	-	-	-	-	-
11,0	87,50	88,50	90,20	91,00	91,00	92,40
15,0	88,50	89,50	90,20	91,00	91,00	93,00
18,5	89,50	90,50	91,00	92,40	91,70	93,60
22,0	89,50	91,00	91,00	92,40	91,70	93,60
30,0	90,20	91,70	91,70	93,00	92,40	94,10
37,0	91,50	92,40	92,40	93,00	93,00	94,50
45,0	91,70	93,00	93,00	93,60	93,60	95,00
55,0	92,40	93,00	93,00	94,10	93,60	95,40
75,0	93,00	93,20	93,60	94,50	94,10	95,40

min⁻¹ ~ 2900

min⁻¹ ~ 3400

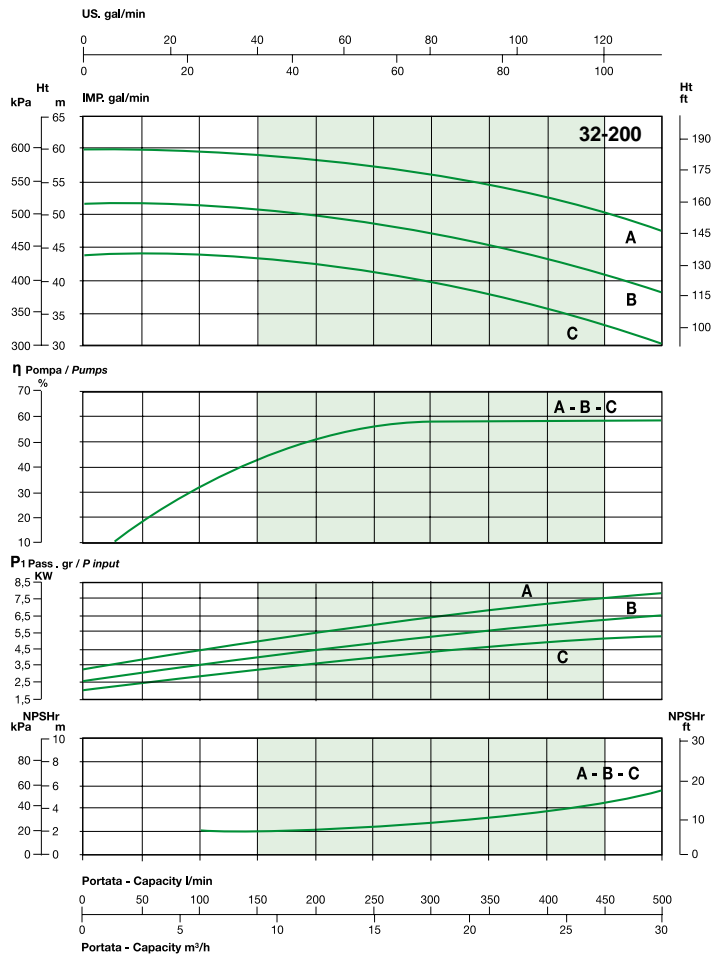
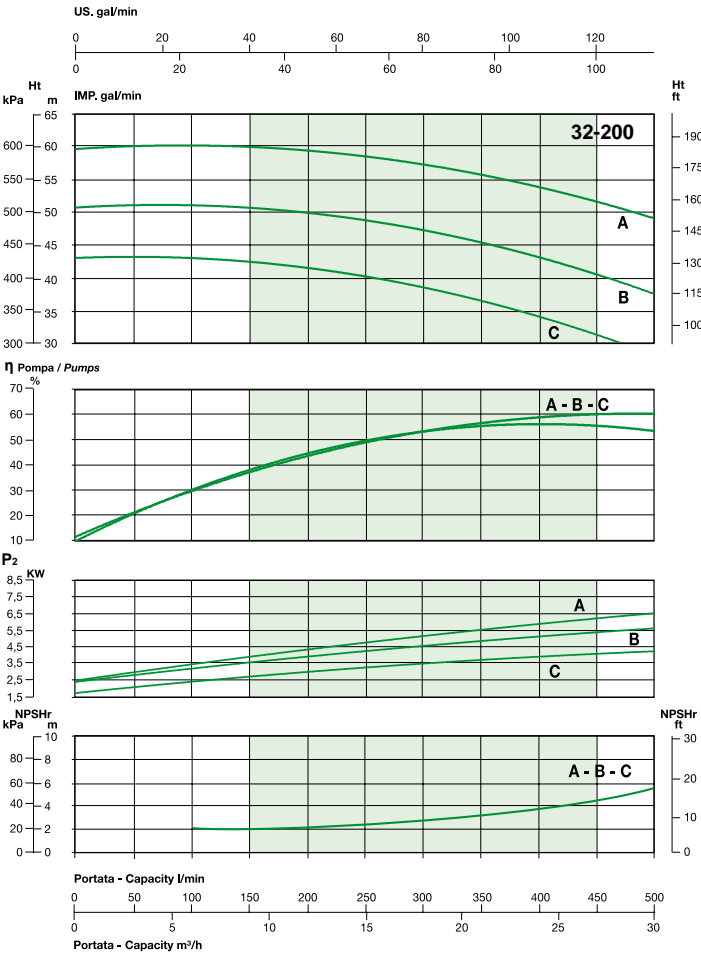
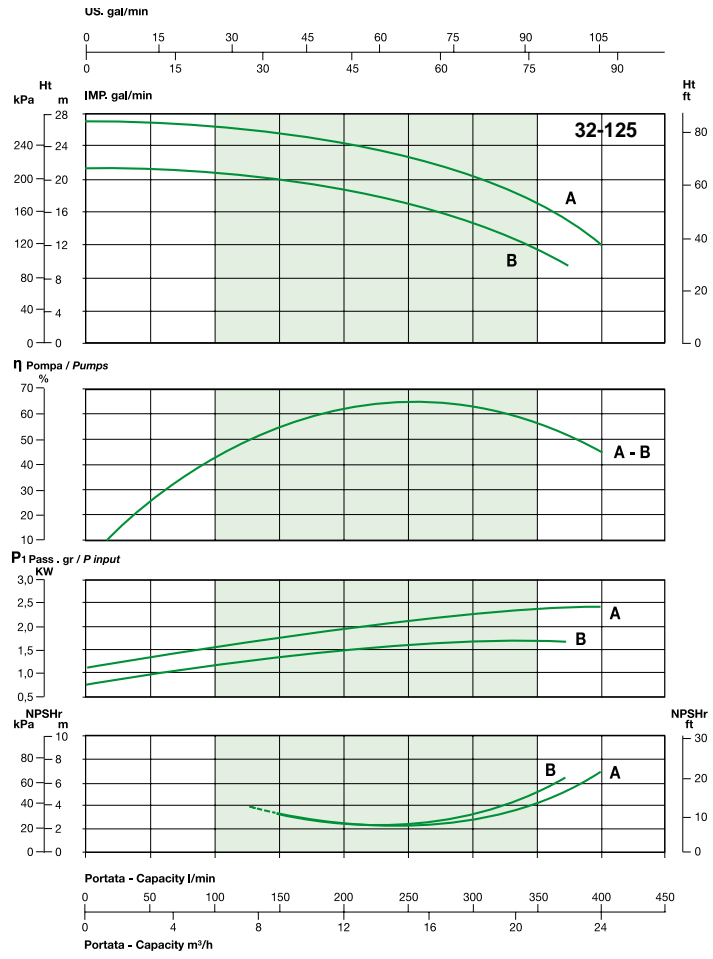
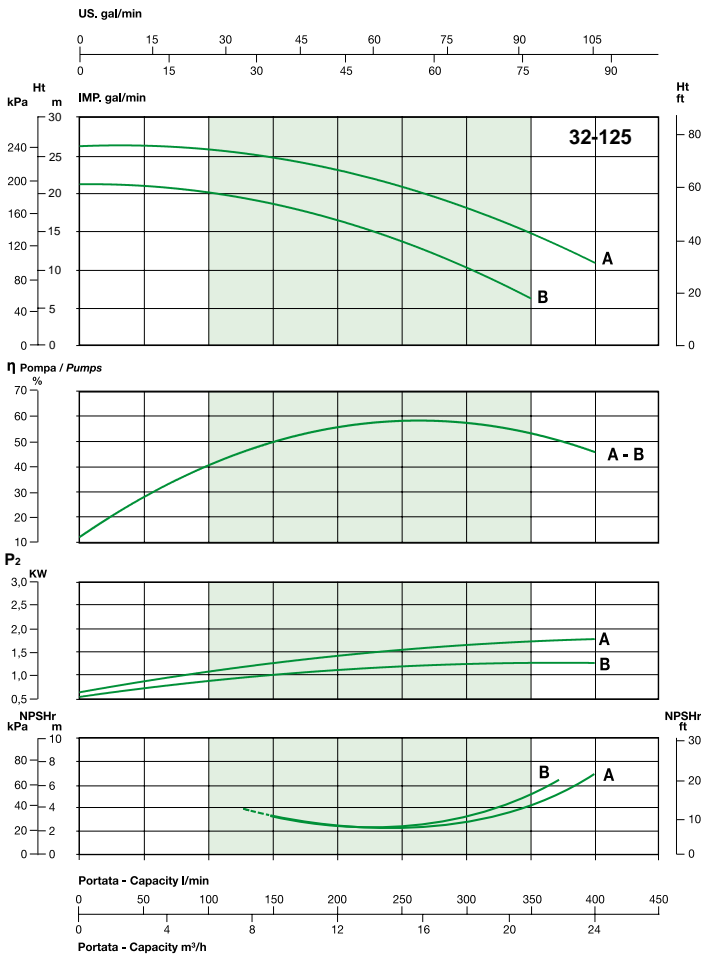

min⁻¹ ~ 2900

min⁻¹ ~ 3400

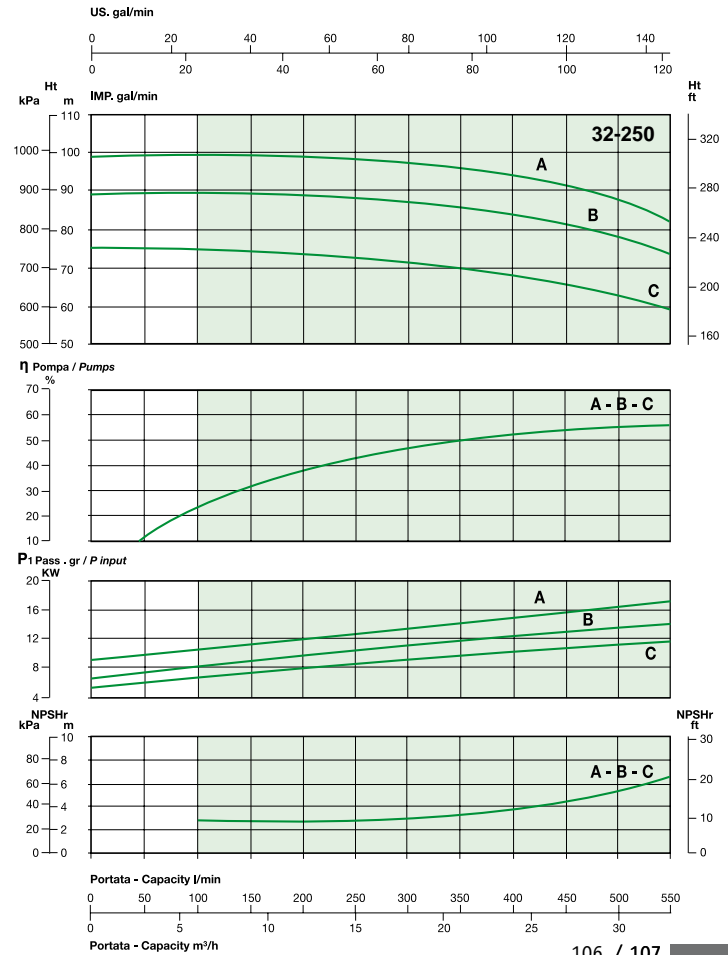
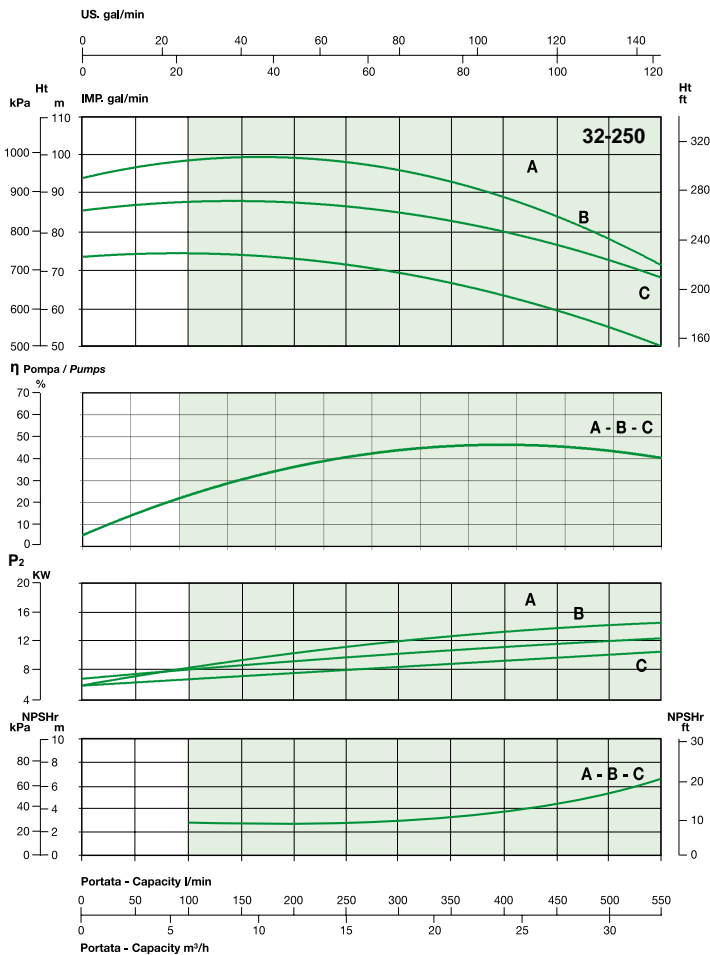
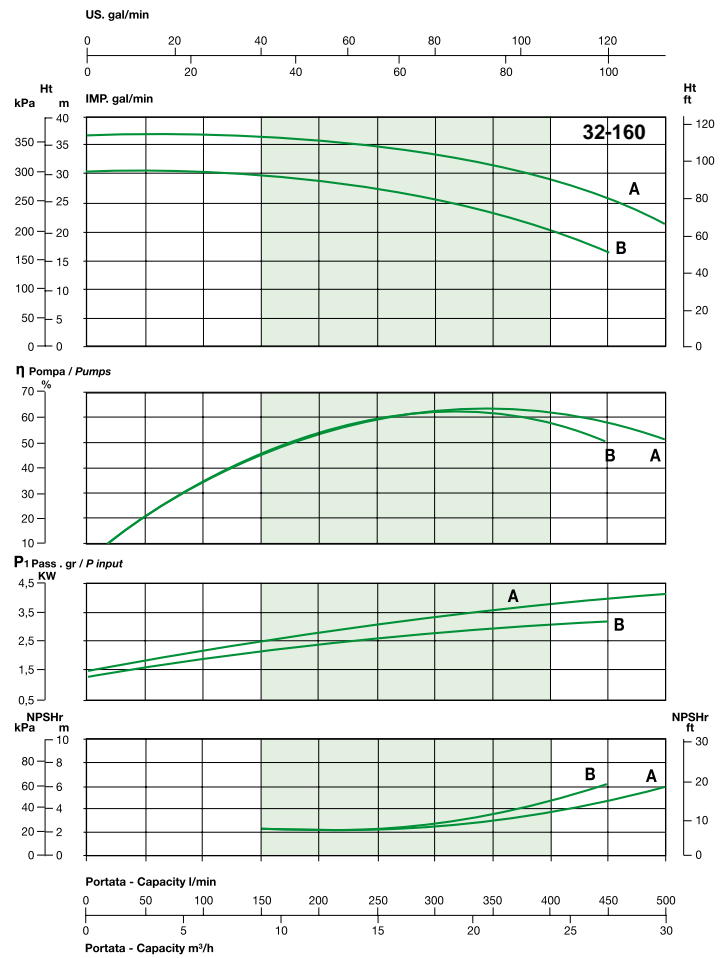
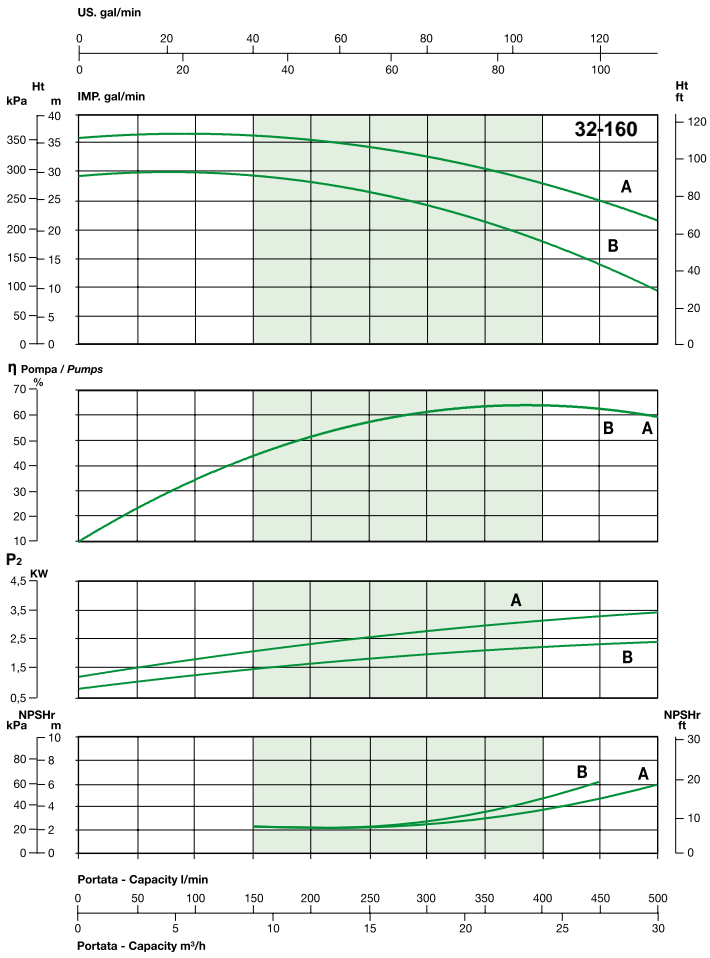

min⁻¹ ~ 2900

min⁻¹ ~ 3400

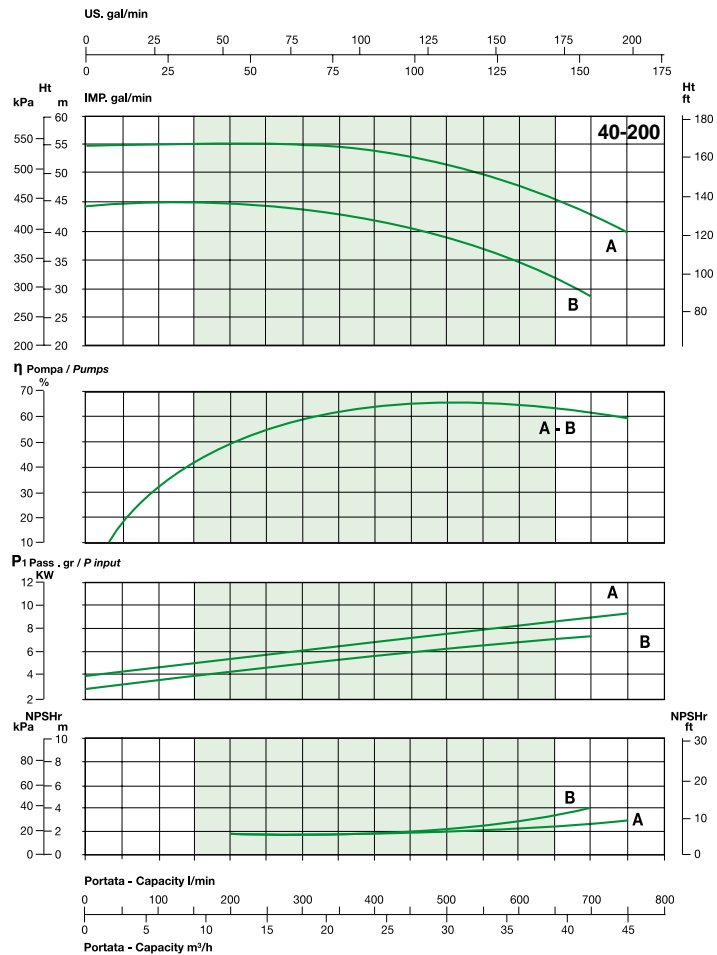
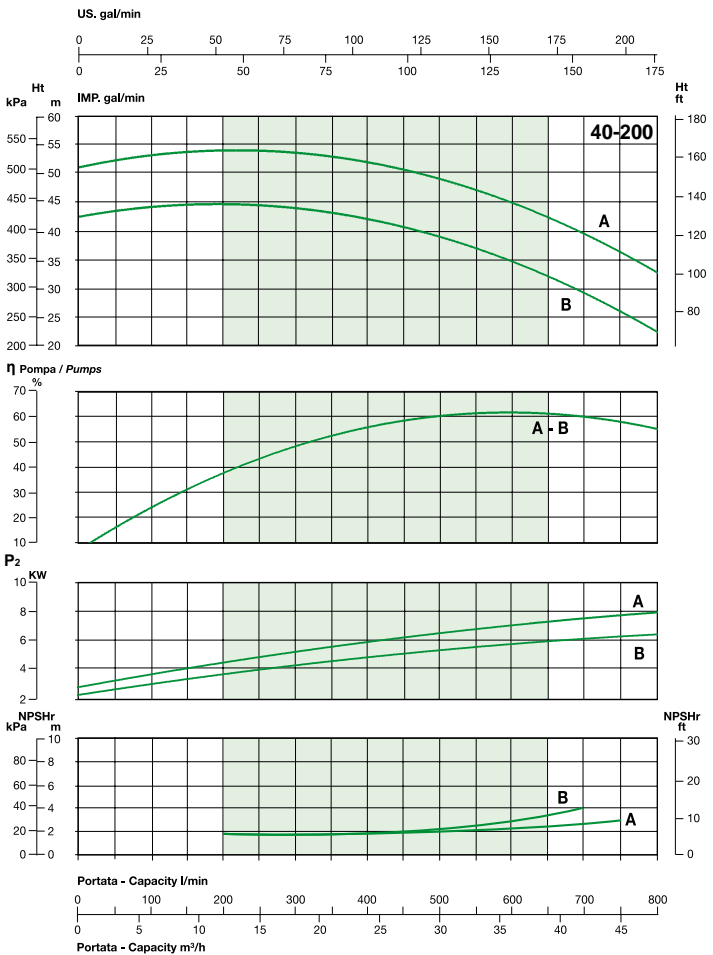
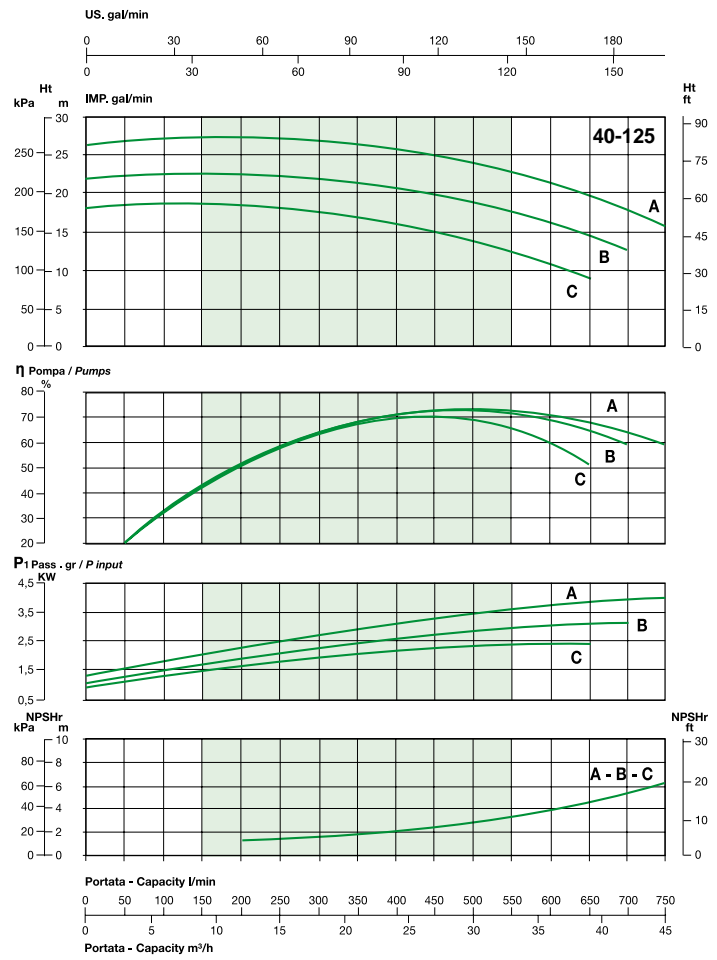
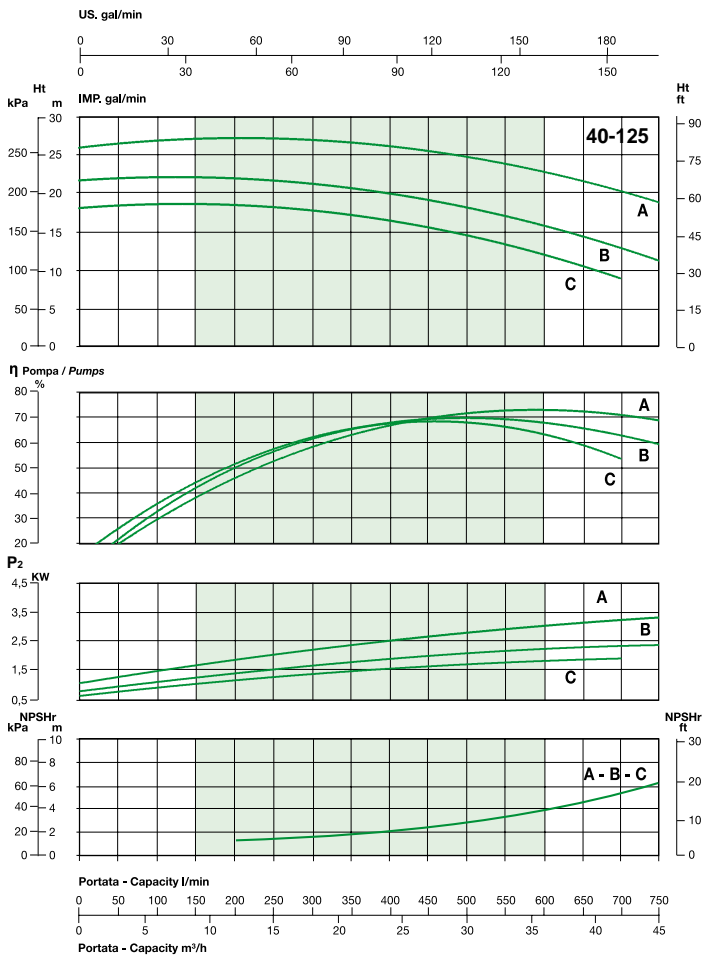

min⁻¹ ~ 2900

min⁻¹ ~ 3400

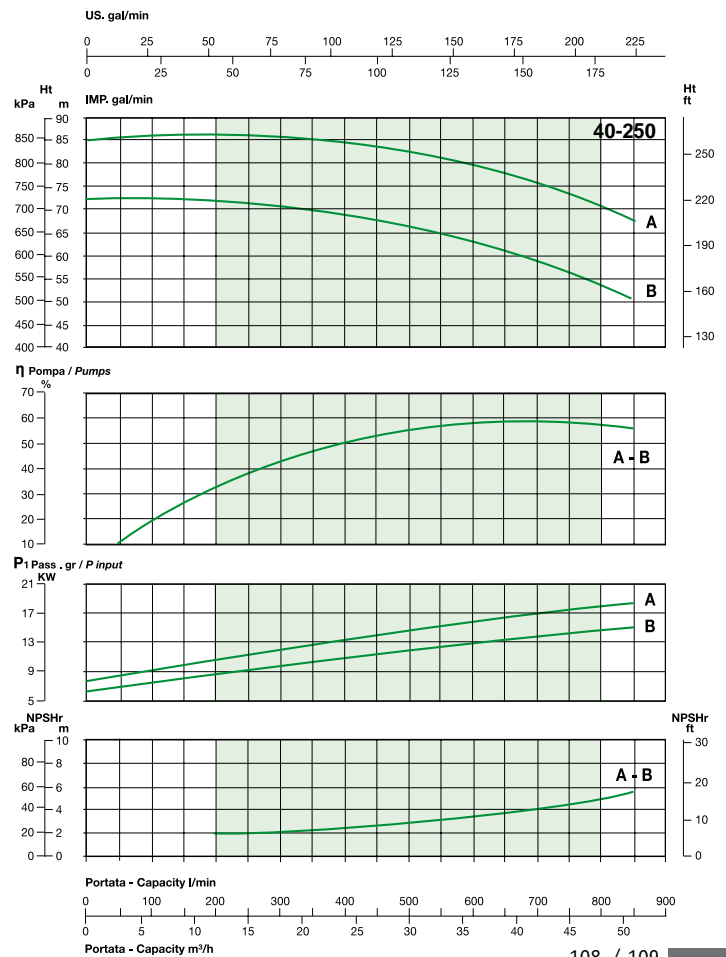
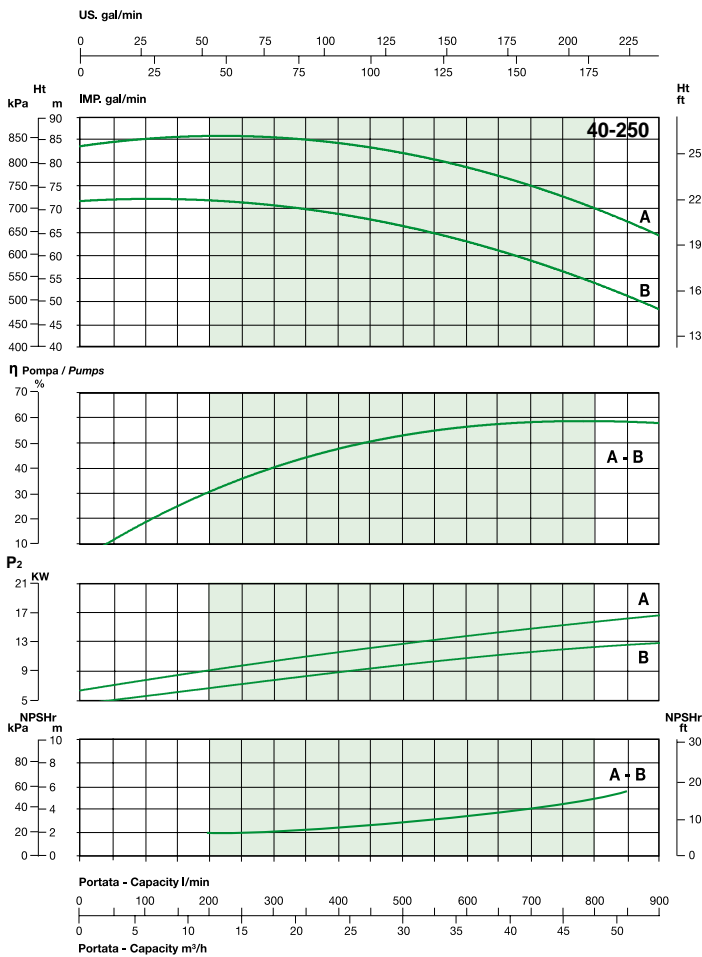
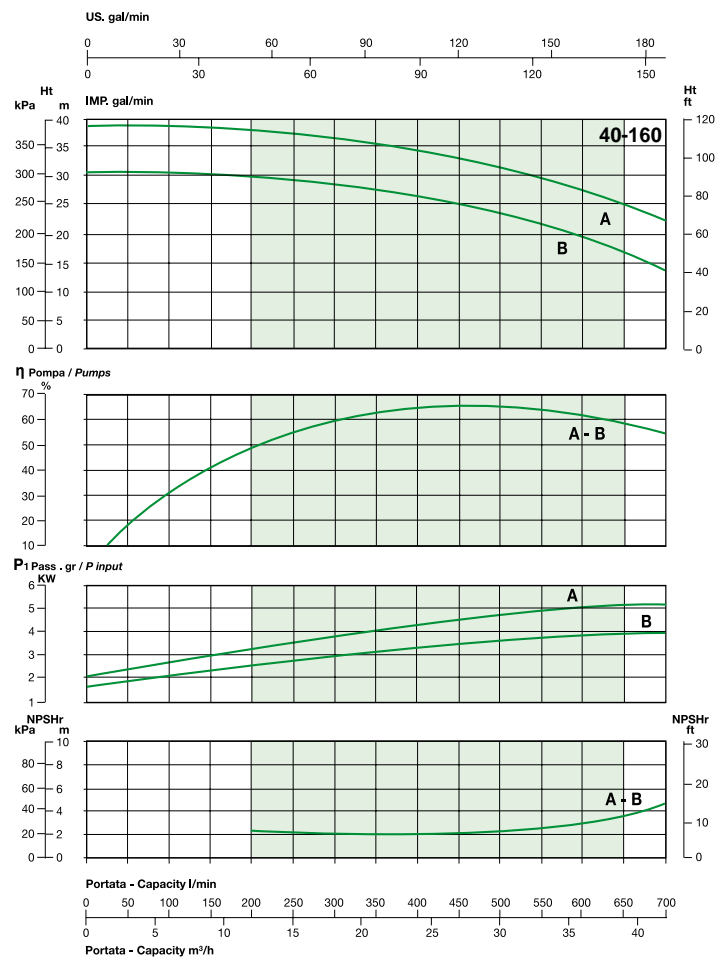
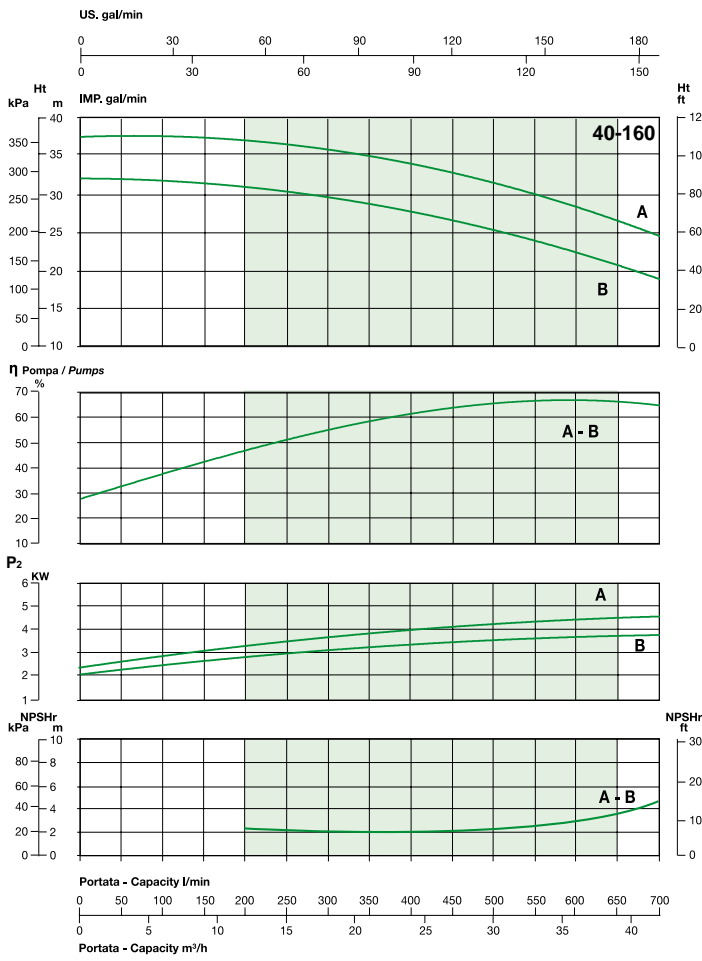

min⁻¹ ~ 2900

min⁻¹ ~ 3400

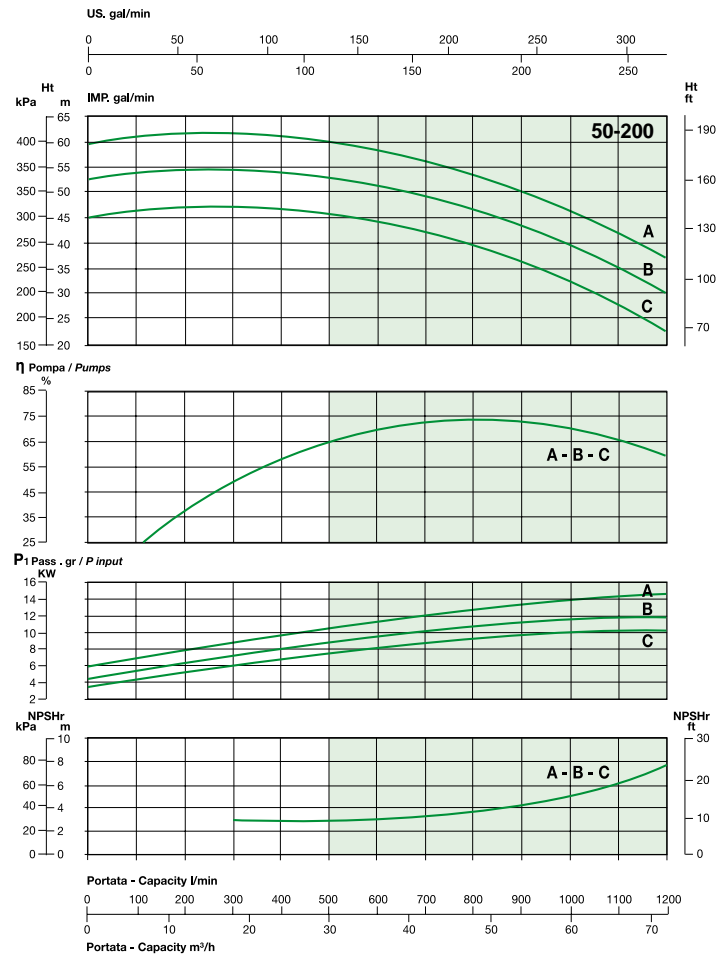
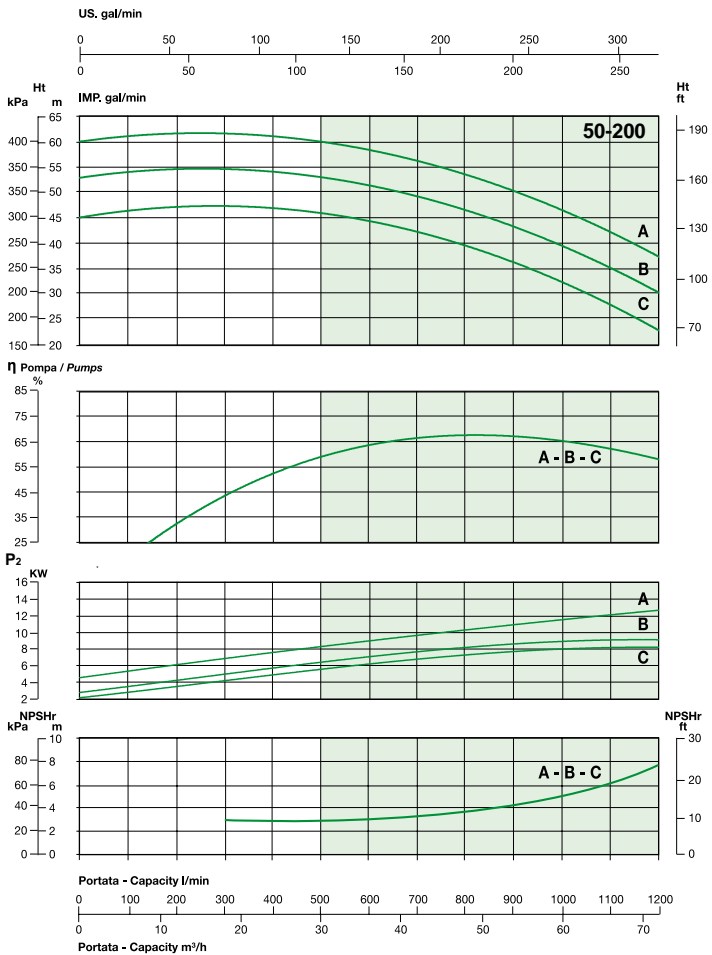
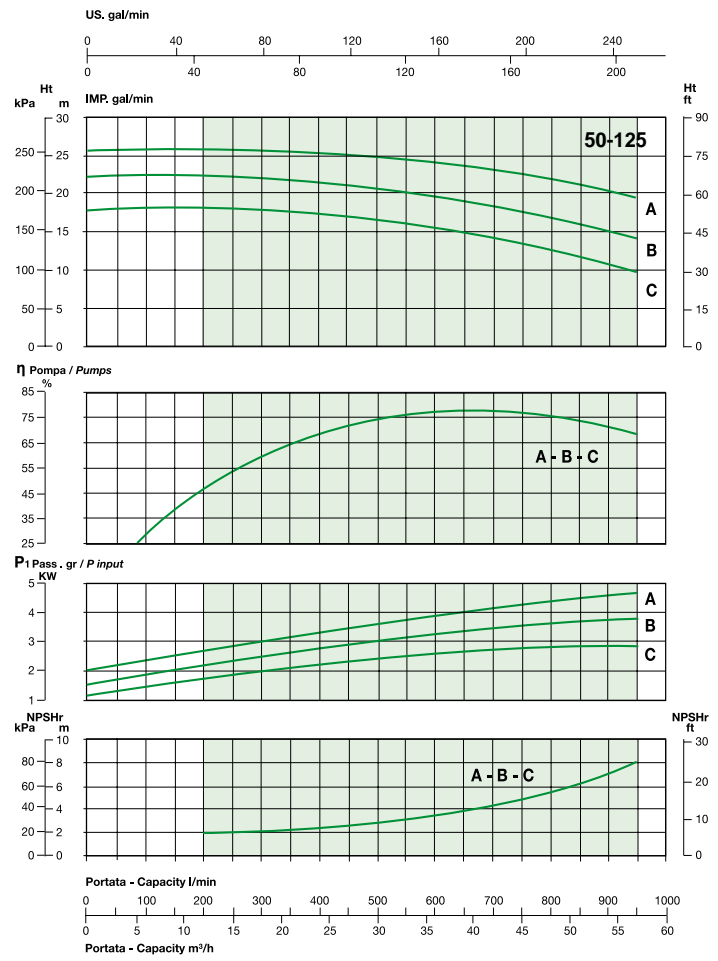
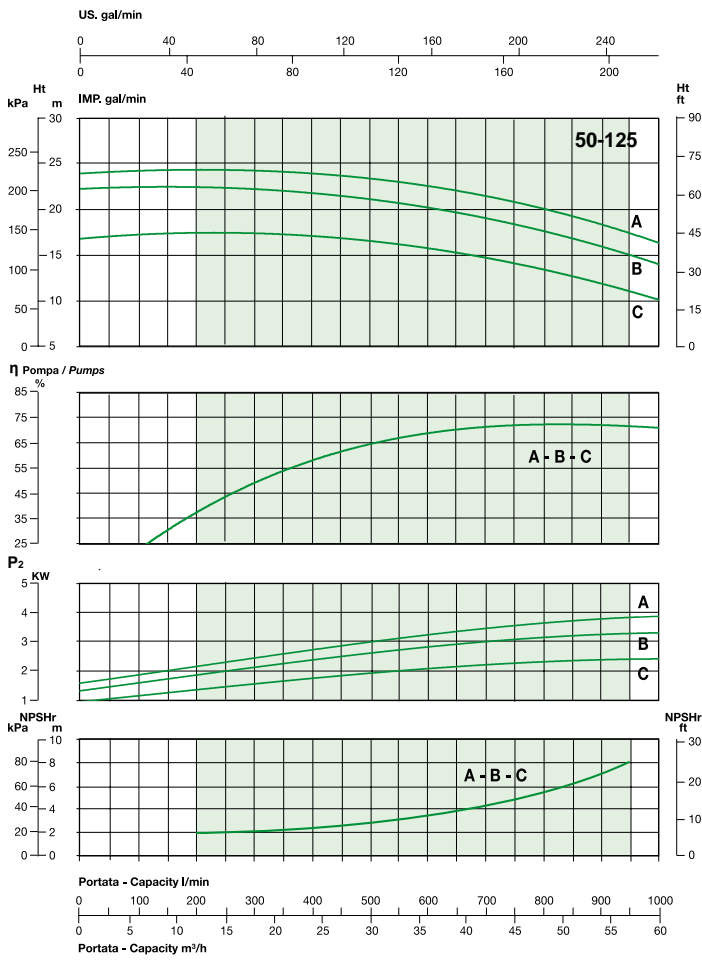

min⁻¹ ~ 2900

min⁻¹ ~ 3400

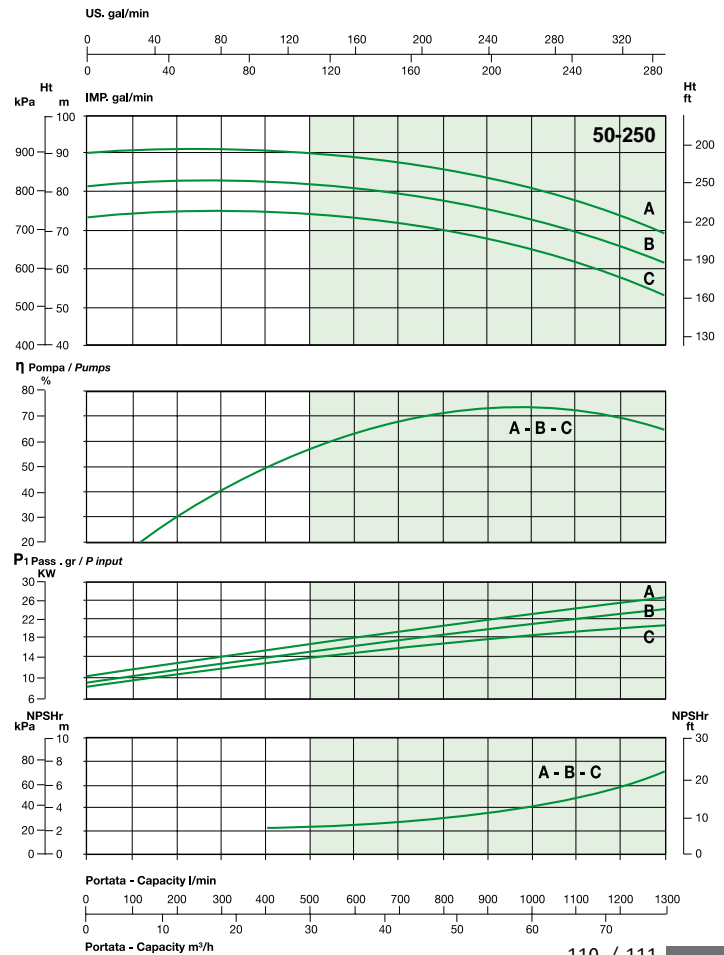
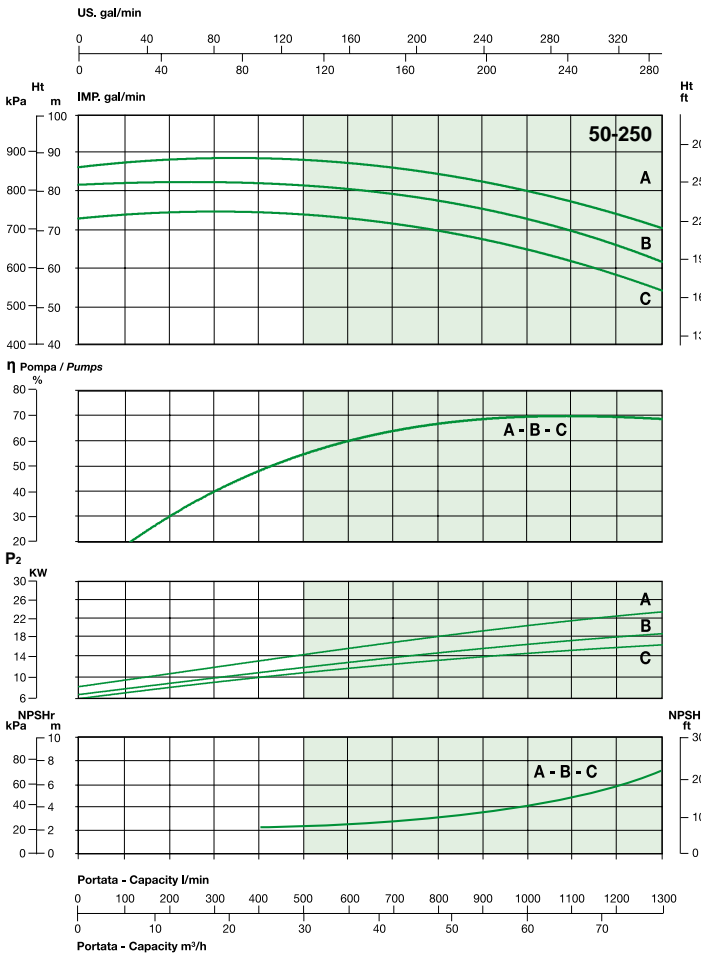
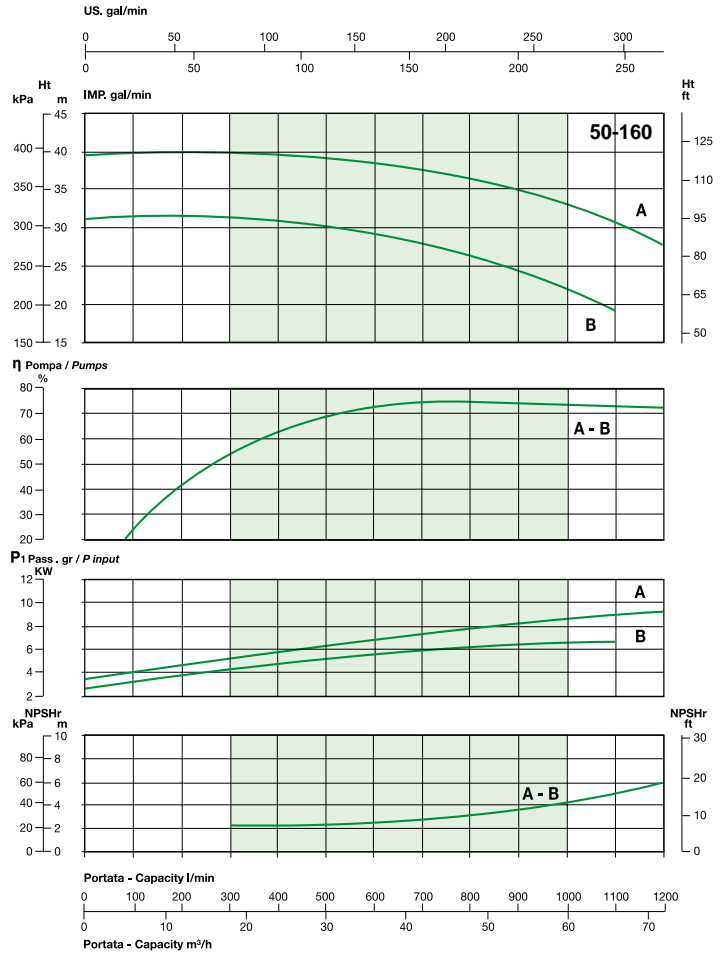
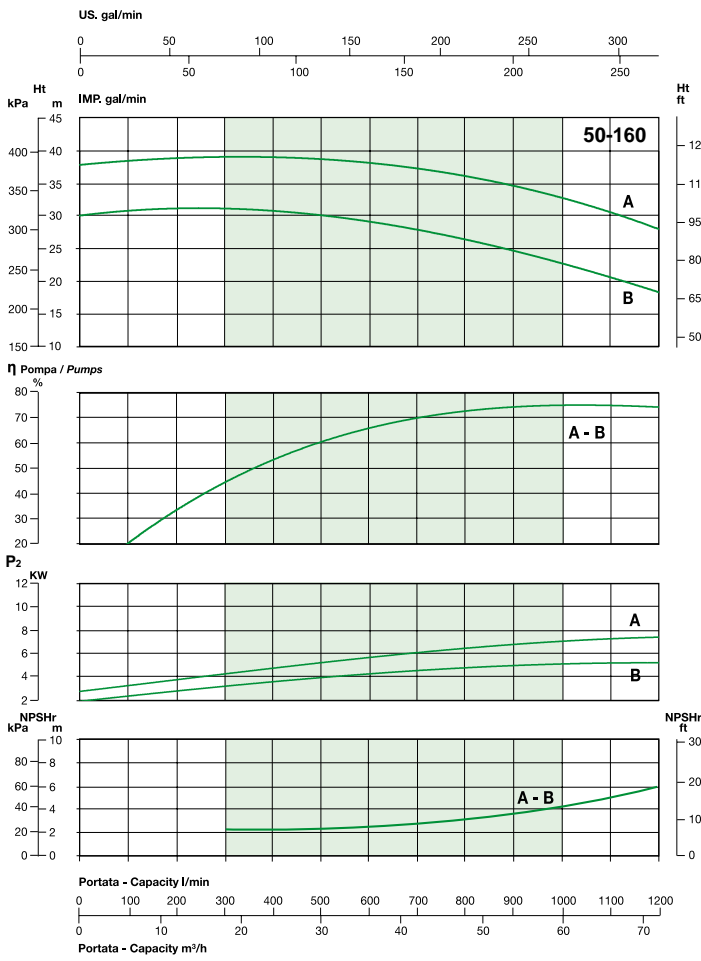

min⁻¹ ~ 2900

min⁻¹ ~ 3400

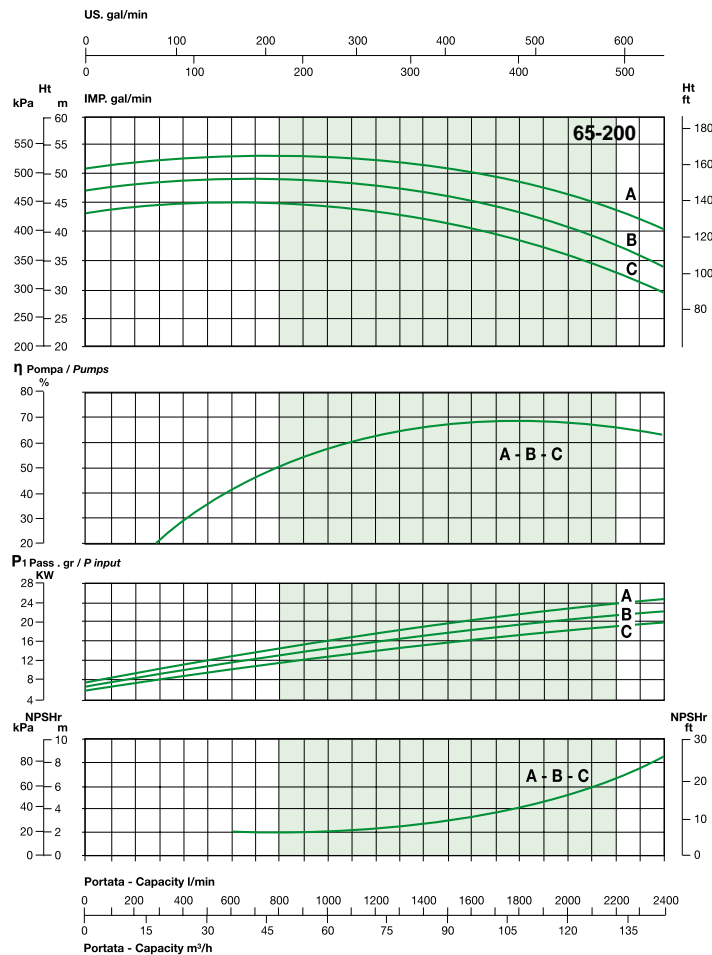
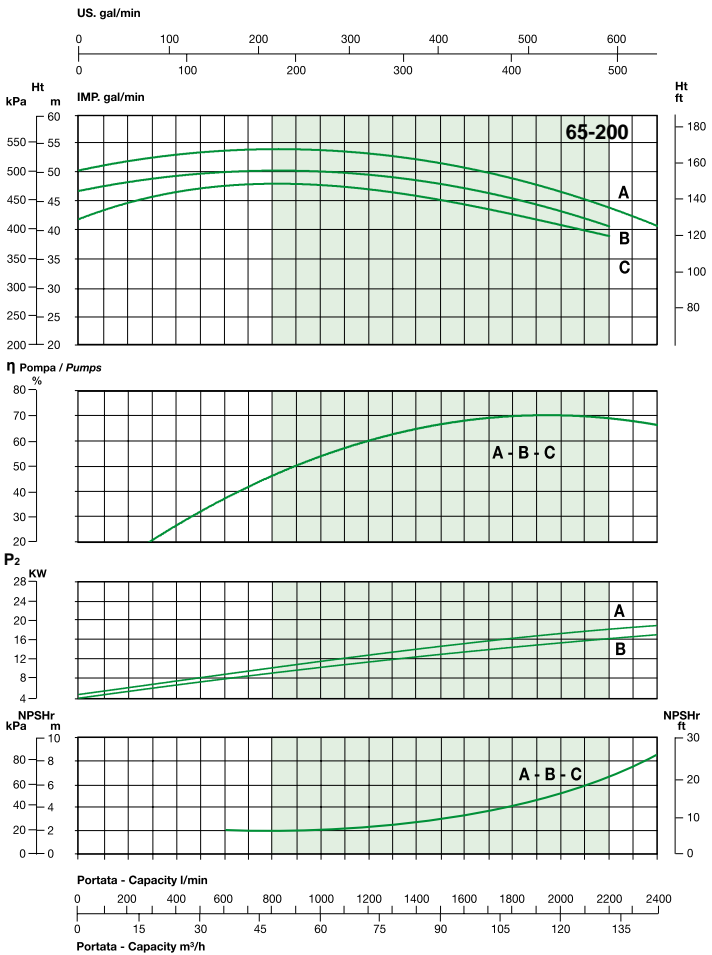
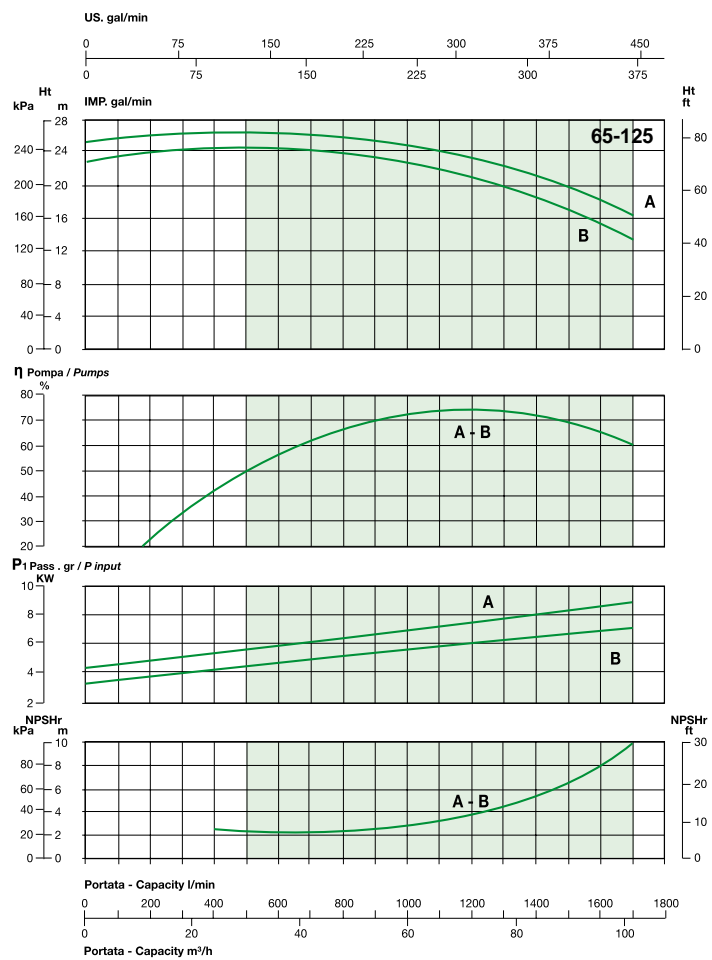
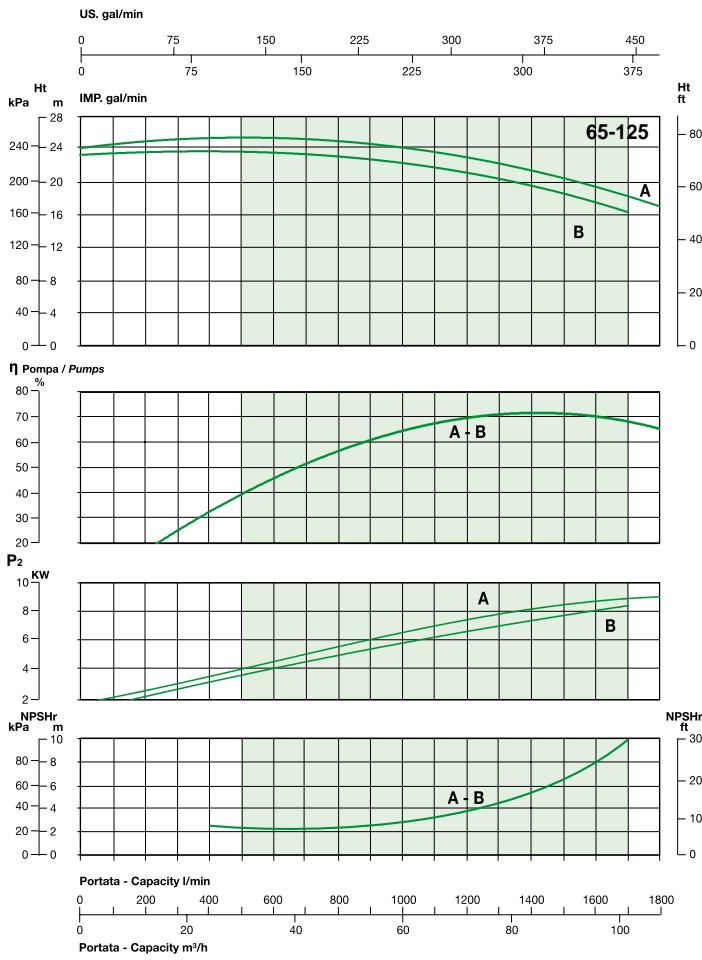

min⁻¹ ~ 2900

min⁻¹ ~ 3400

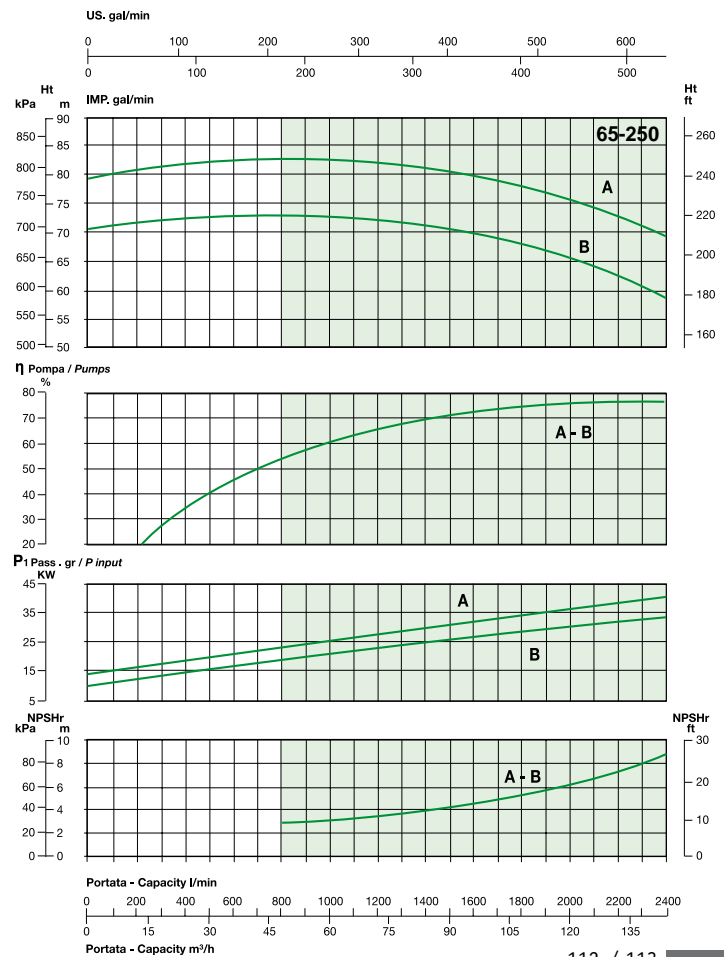
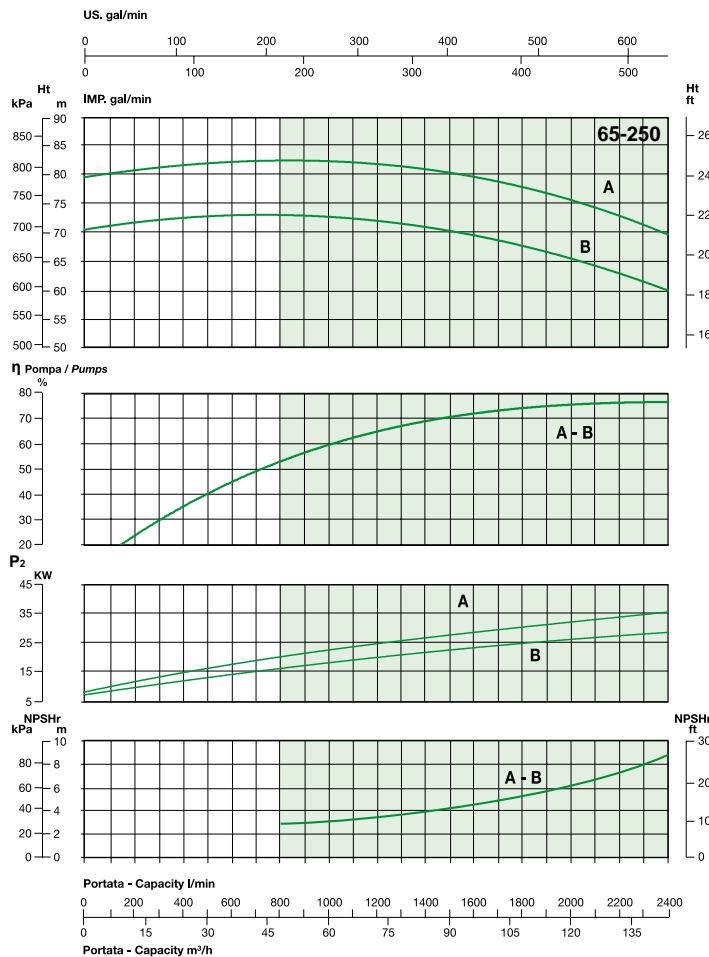
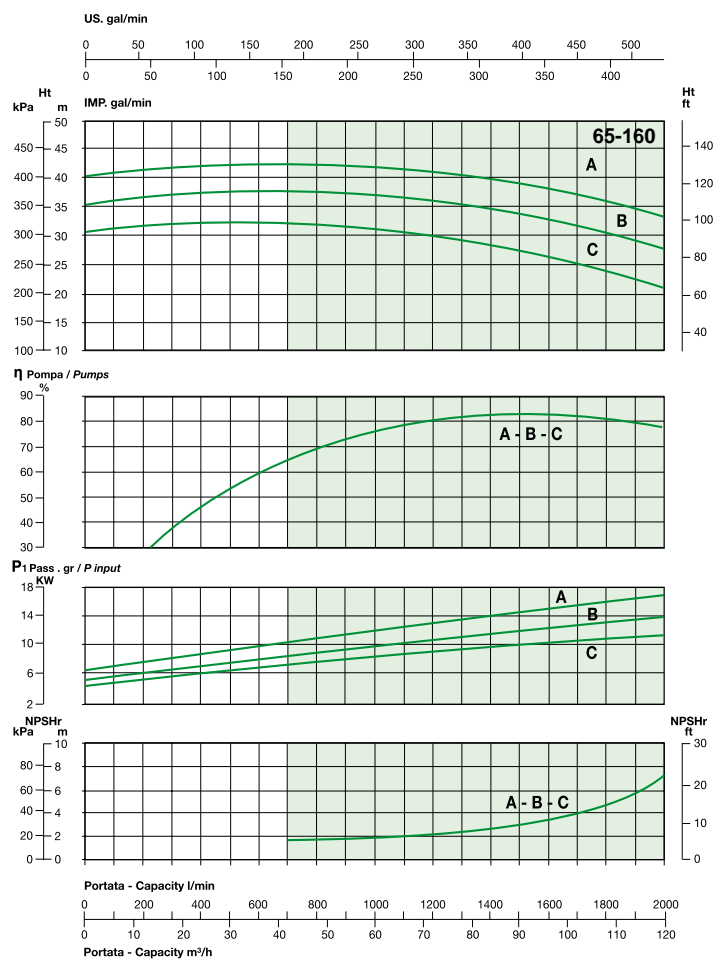
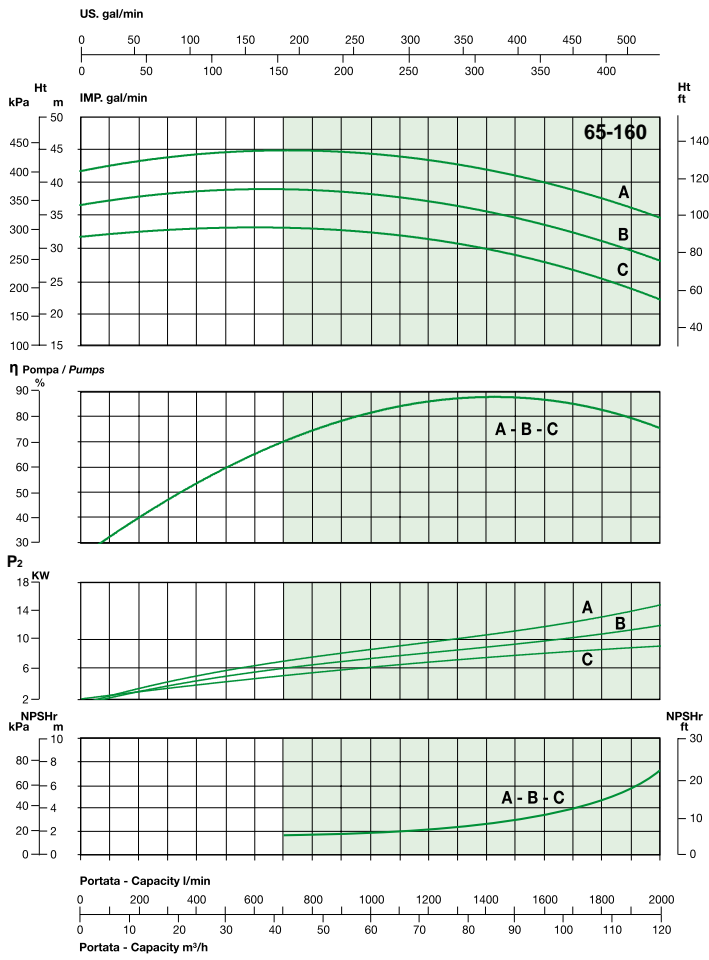

min⁻¹ ~ 2900

min⁻¹ ~ 3400

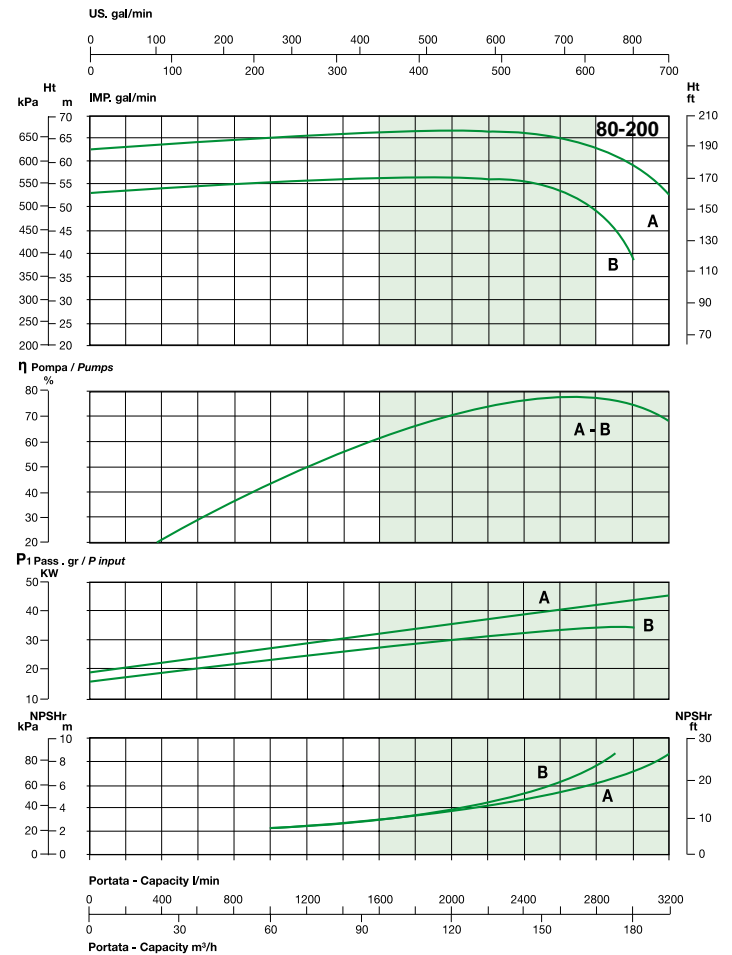
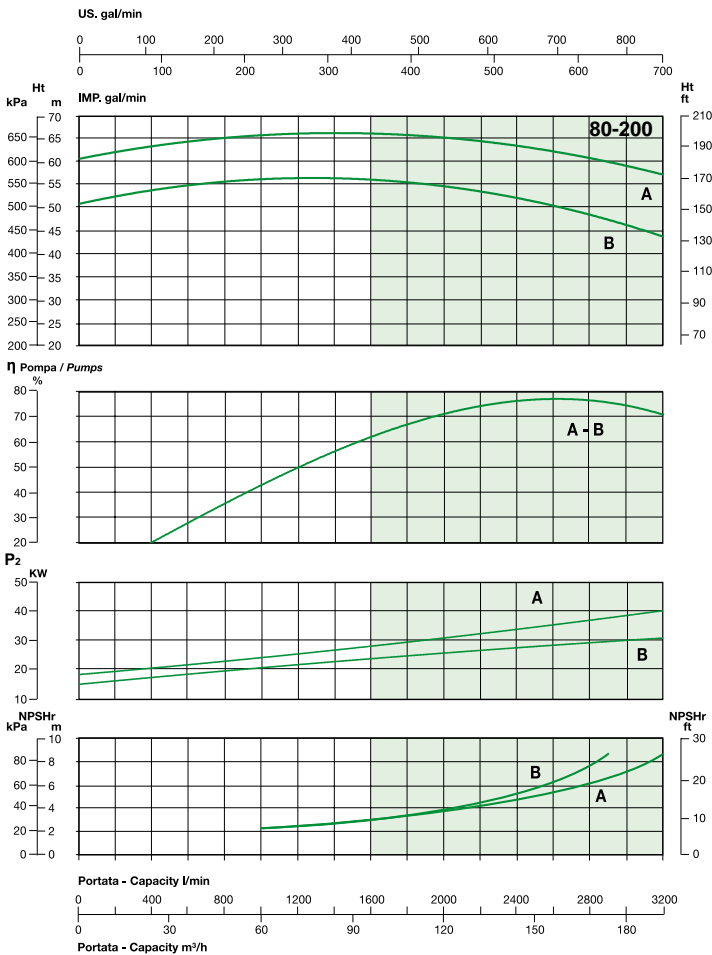
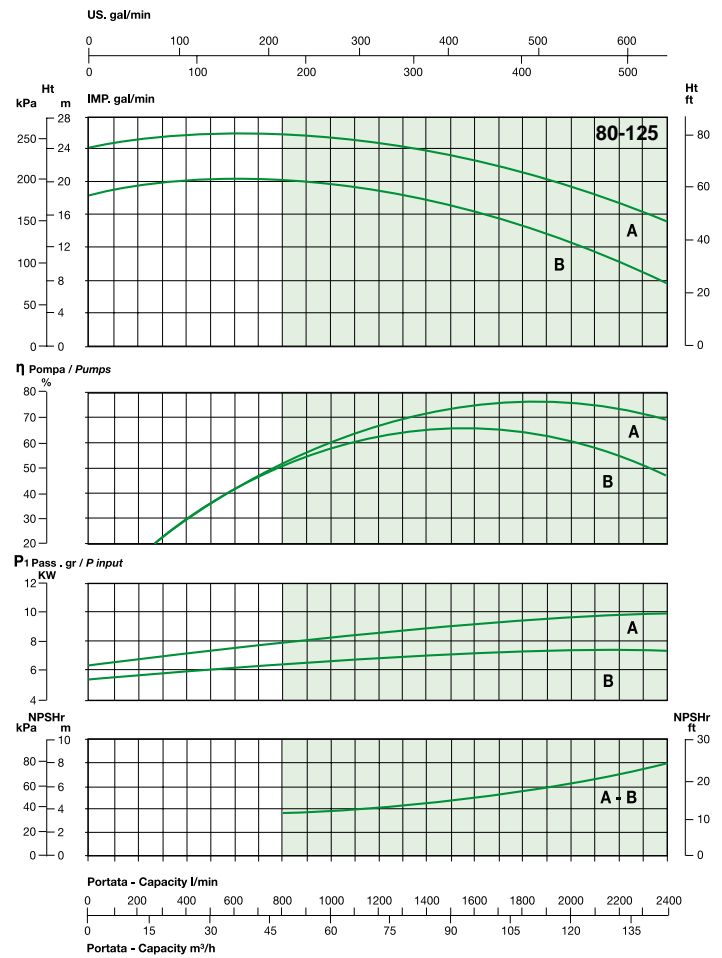
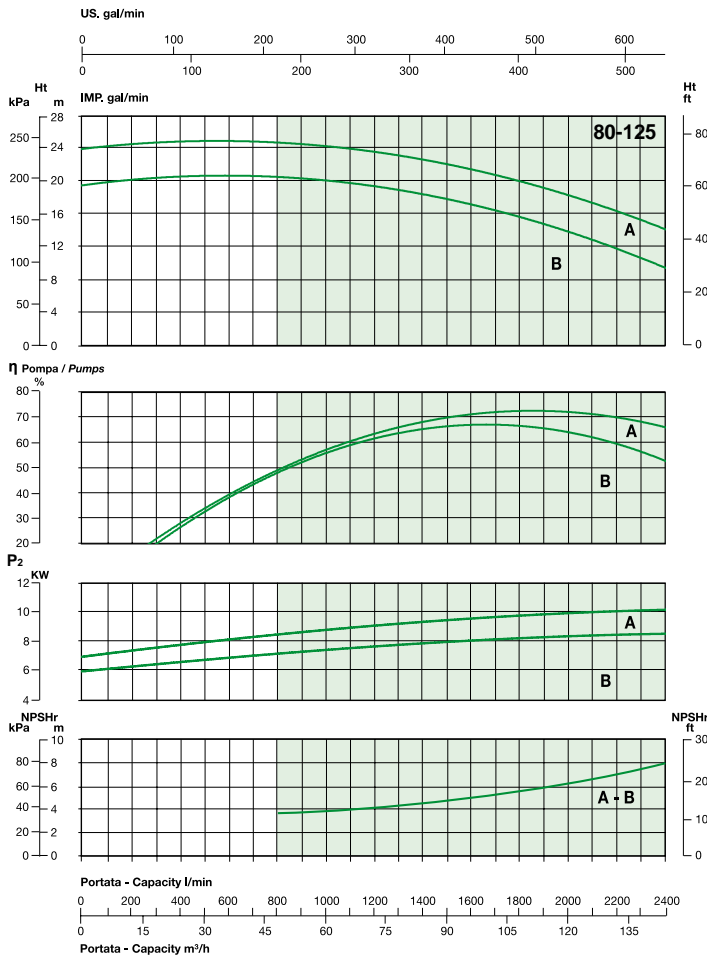

min⁻¹ ~ 2900

min⁻¹ ~ 3400

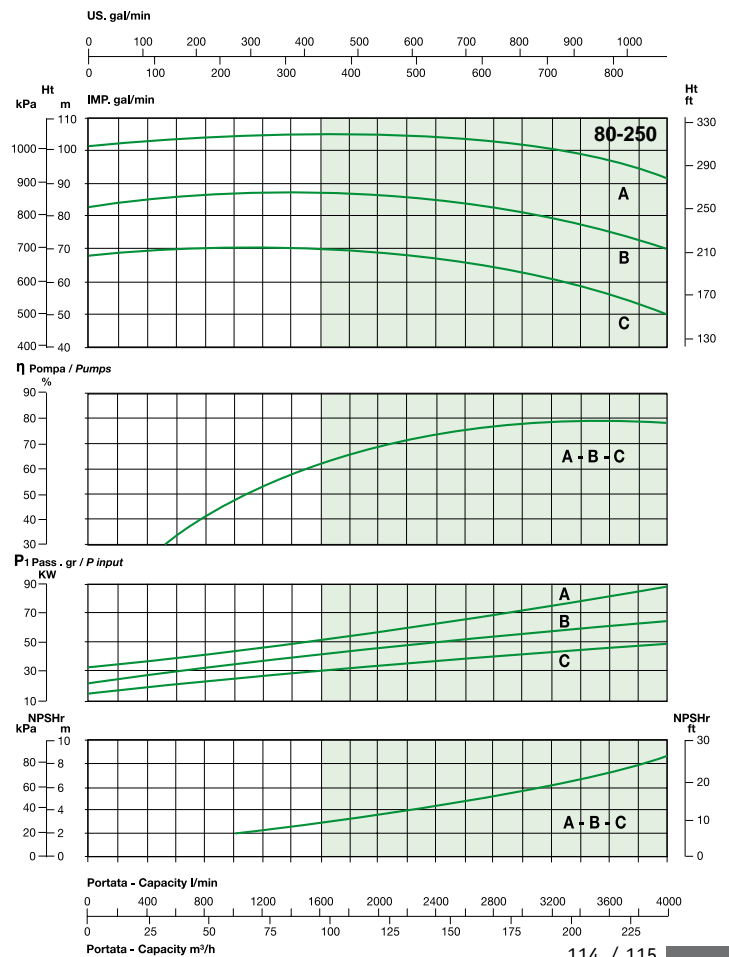
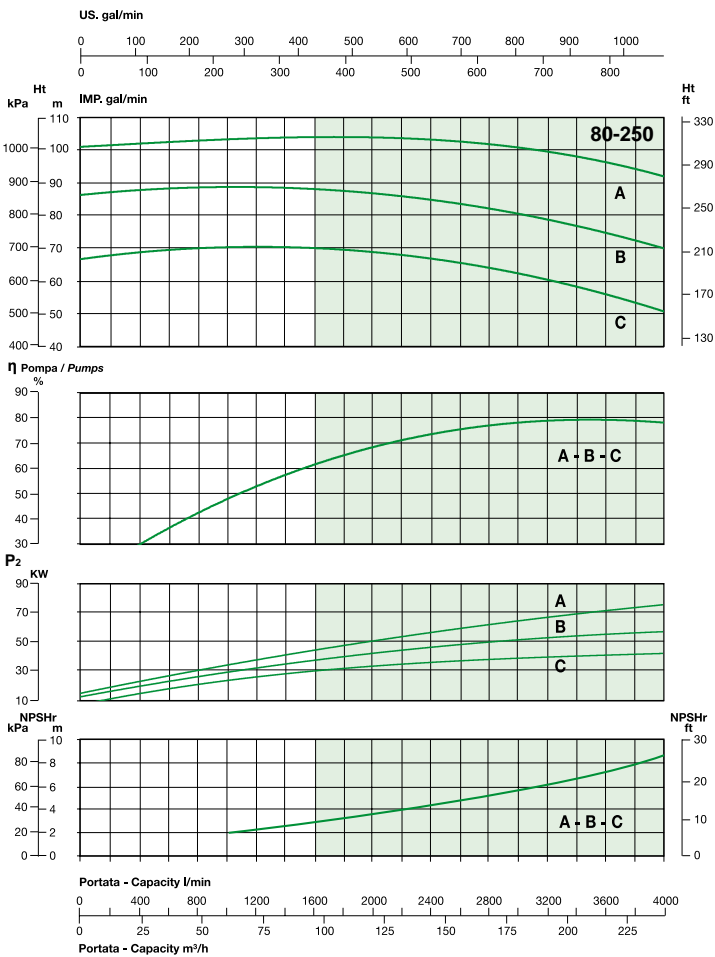
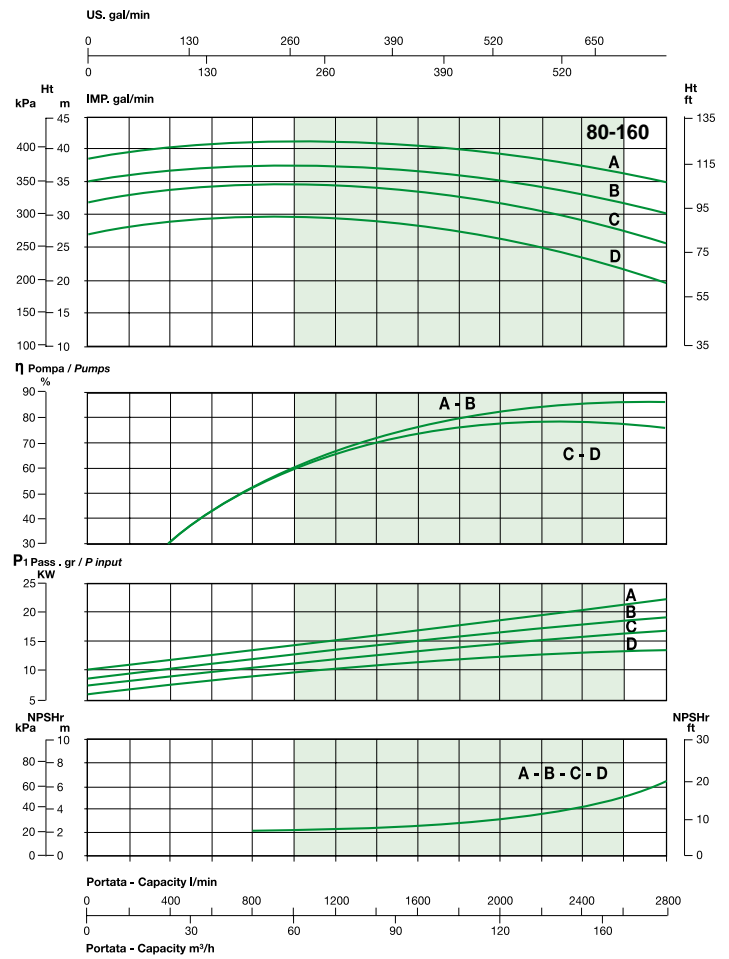
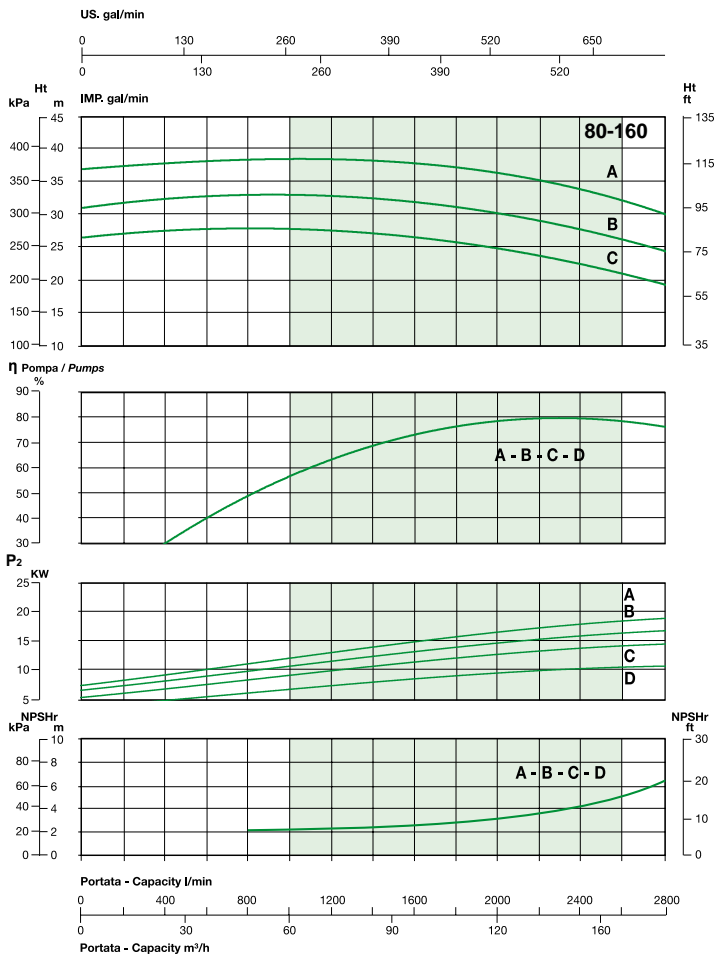

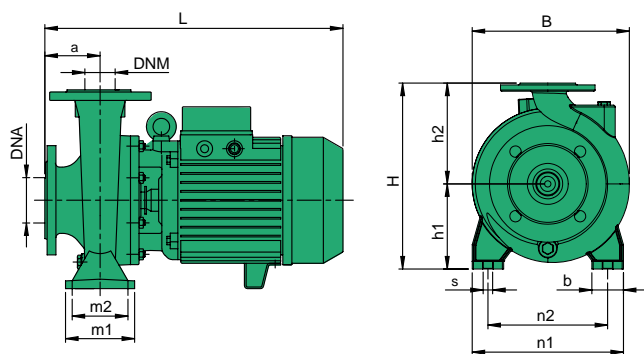

Flange - Flanges - Brides - Bridas
mm

DN	K	D	B	fori - holes - orifices - orificios n°	Ø
32	100	140	18	4	18
40	110	150	18	4	18
50	125	165	19	4	18
65	145	185	19	4	18
80	160	200	22	4	18
100	180	220	24	8	18

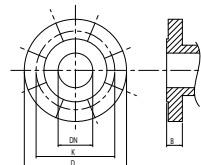

TIPO TYPE	DIMENSIONI [mm] DIMENSIONS [mm]														IMBALLO [mm] PACKING [mm]			PESO WEIGHT [kg]
	a	b	s	L	B	H	n1	n2	m1	m2	h1	h2	DNA	DNM	A	L	P	
CN 32 125B	80	50	14	400	203	252	190	140	100	70	112	140	50	32	380	290	520	38
CN 32 125A	80	50	14	400	203	252	190	140	100	70	112	140	50	32	380	290	520	40
CN 32 160B	80	50	14	437	240	292	240	190	100	70	132	160	50	32	380	290	520	43,5
CN 32 160A	80	50	14	400	240	292	240	190	100	70	132	160	50	32	380	290	520	51
CN 32 200C	80	50	14	468	273	340	240	190	100	70	160	180	50	32	380	290	520	55,5
CN 32 200B	80	50	14	495	273	340	240	190	100	70	160	180	50	32	550	350	580	67,5
CN 32 200A	80	50	14	537	273	340	240	190	100	70	160	180	50	32	560	350	700	81,5
CN 32 250C	100	65	14	561	326	405	320	250	125	95	180	225	50	32	560	350	700	98
CN 32 250B	100	65	14	600	326	405	320	250	125	95	180	225	50	32	560	350	700	105
CN 32 250A	100	65	14	682	326	405	320	250	125	95	180	225	50	32	570	470	890	148
CN 40 125C	80	50	14	400	216	252	210	160	100	70	112	140	65	40	380	290	520	38
CN 40 125B	80	50	14	437	216	252	210	160	100	70	112	140	65	40	380	290	520	43
CN 40 125A	80	50	14	463	216	252	210	160	100	70	112	140	65	40	380	290	520	48
CN 40 160B	80	50	14	463	242	292	240	190	100	70	132	160	65	40	380	290	520	50
CN 40 160A	80	50	14	463	242	292	240	190	100	70	132	160	65	40	380	290	520	52
CN 40 200B	100	50	14	515	278	340	265	212	100	70	160	180	65	40	550	350	580	71
CN 40 200A	100	50	14	557	278	340	265	212	100	70	160	180	65	40	560	350	700	84,5
CN 40 250B	100	65	14	600	328	405	320	250	125	95	180	225	65	40	560	350	700	104,5
CN 40 250A	100	65	14	682	328	405	320	250	125	95	180	225	65	40	570	470	890	149
CN 50 125C	100	50	14	457	248	292	240	190	100	70	132	160	65	50	380	290	520	45
CN 50 125B	100	50	14	483	248	292	240	190	100	70	132	160	65	50	380	290	520	41,5
CN 50 125A	100	50	14	483	248	292	240	190	100	70	132	160	65	50	380	290	520	52
CN 50 160B	100	50	14	515	268	340	265	212	100	70	160	180	65	50	550	350	580	67,5
CN 50 160A	100	50	14	557	268	340	265	212	100	70	160	180	65	50	560	350	700	80,5
CN 50 200C	100	50	14	561	290	360	265	212	100	70	160	200	65	50	560	350	700	92,5
CN 50 200B	100	50	14	600	290	360	265	212	100	70	160	200	65	50	560	350	700	99,5
CN 50 200A	100	50	14	682	290	360	265	212	100	70	160	200	65	50	570	470	890	141
CN 50 250C	100	65	14	682	334	405	320	250	125	95	180	225	65	50	570	470	890	151
CN 50 250B	100	65	14	682	334	405	320	250	125	95	180	225	65	50	570	470	890	156
CN 50 250A	100	65	14	726	334	405	320	250	125	95	180	225	65	50	570	470	890	168
CN 65 125B	100	65	14	515	283	340	280	212	125	95	160	180	80	65	550	350	580	68,5
CN 65 125A	100	65	14	557	283	340	280	212	125	95	160	180	80	65	560	350	700	81,5
CN 65 160C	100	65	14	565	290	360	280	212	125	95	160	200	80	65	560	350	700	92,5
CN 65 160B	100	65	14	605	290	360	280	212	125	95	160	200	80	65	560	350	700	99
CN 65 160A	100	65	14	686	290	360	280	212	125	95	160	200	80	65	570	470	890	142
CN 65 200C	100	65	14	686	330	405	320	250	125	95	180	225	80	65	570	470	890	144,5
CN 65 200B	100	65	14	686	330	405	320	250	125	95	180	225	80	65	570	470	890	151
CN 65 200A	100	65	14	730	330	405	320	250	125	95	180	225	80	65	570	470	890	162
CN 80 125B	100	65	14	520	285	340	280	212	125	95	160	180	100	80	550	350	580	73
CN 80 125A	100	65	14	561	285	340	280	212	125	95	160	180	100	80	560	350	700	86
CN 80 160D	125	65	14	628	330	405	320	250	125	95	180	225	100	80	560	350	700	106
CN 80 160C	125	65	14	710	330	405	320	250	125	95	180	225	100	80	570	470	890	147,5
CN 80 160B	125	65	14	710	330	405	320	250	125	95	180	225	100	80	570	470	890	153,5
CN 80 160A	125	65	14	755	330	405	320	250	125	95	180	225	100	80	570	470	890	164,5

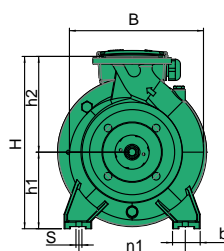
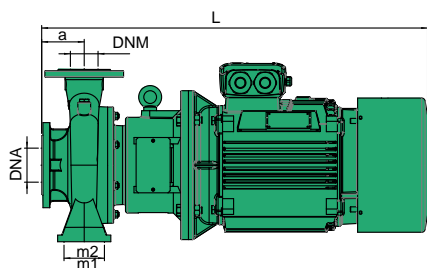

Flange - Flanges - Brides - Bidas
mm

DN	K	D	B	fori - holes - orifices - orificios	
				n°	∅
32	100	140	18	4	18
40	110	150	18	4	18
50	125	165	19	4	18
65	145	185	19	4	18
80	160	200	22	4	18
100	180	220	24	8	18

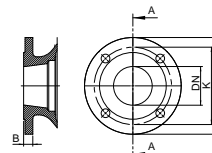

TIPO TYPE	DIMENSIONI [mm] DIMENSIONS [mm]														IMBALLO [mm] PACKING [mm]			PESO WEIGHT [kg]
	a	b	s	L	B	H	n1	n2	m1	m2	h1	h2	DNA	DNM	A	L	P	
CNG 32 200B	80	50	14	700	273	340	240	190	100	70	160	180	50	32	420	360	760	103
CNG 32 200A	80	50	14	740	273	340	240	190	100	70	160	180	50	32	420	360	760	109,5
CNG 32 250C	100	65	14	760	326	405	320	250	125	95	180	225	50	32	580	510	970	136
CNG 32 250B	100	65	14	800	326	405	320	250	125	95	180	225	50	32	580	510	970	193,5
CNG 32 250A	100	65	14	890	326	405	320	250	125	95	180	225	50	32	580	510	970	204
CNG 40 200B	100	50	14	720	278	340	265	212	100	70	160	180	65	40	420	360	760	106
CNG 40 200A	100	50	14	760	278	340	265	212	100	70	160	180	65	40	420	360	760	112
CNG 40 250B	100	65	14	800	328	405	320	250	125	95	180	225	65	40	580	510	970	195
CNG 40 250A	100	65	14	890	328	405	320	250	125	95	180	225	65	40	580	510	970	205,5
CNG 50 160B	100	50	14	720	268	340	265	212	100	70	160	180	65	50	420	360	760	102,5
CNG 50 160A	100	50	14	760	268	340	265	212	100	70	160	180	65	50	420	360	760	109
CNG 50 200C	100	50	14	760	290	360	265	212	100	70	160	200	65	50	580	510	970	130
CNG 50 200B	100	50	14	800	290	360	265	212	100	70	160	200	65	50	580	510	970	187,5
CNG 50 200A	100	50	14	890	290	360	265	212	100	70	160	200	65	50	580	510	970	198
CNG 50 250C	100	65	14	890	334	405	320	250	125	95	180	225	65	50	580	510	970	205
CNG 50 250B	100	65	14	890	334	405	320	250	125	95	180	225	65	50	650	570	1080	226
CNG 50 250A	100	65	14	930	334	405	320	250	125	95	180	225	65	50	650	570	1080	257
CNG 65 125B	100	65	14	720	283	340	280	212	125	95	160	180	80	65	420	360	760	102
CNG 65 125A	100	65	14	760	283	340	280	212	125	95	160	180	80	65	420	360	760	108,5
CNG 65 160C	100	65	14	765	290	360	280	212	125	95	160	200	80	65	580	510	970	131
CNG 65 160B	100	65	14	810	290	360	280	212	125	95	160	200	80	65	580	510	970	188,5
CNG 65 160A	100	65	14	890	290	360	280	212	125	95	160	200	80	65	580	510	970	199
CNG 65 200C	100	65	14	890	330	405	320	250	125	95	180	225	80	65	580	510	970	201,5
CNG 65 200B	100	65	14	890	330	405	320	250	125	95	180	225	80	65	650	570	1080	222
CNG 65 200A	100	65	14	930	330	405	320	250	125	95	180	225	80	65	650	570	1080	252,5
CNG 65 250B	100	80	18	1062	375	450	360	280	160	120	200	250	80	65	770	680	1300	318,5
CNG 65 250A	100	80	18	1062	375	450	360	280	160	120	200	250	80	65	770	680	1300	345,5
CNG 80 125B	100	65	14	720	285	340	280	212	125	95	160	180	100	80	420	360	760	105
CNG 80 125A	100	65	14	861	285	340	280	212	125	95	160	180	100	80	420	360	760	111,5
CNG 80 160D	125	65	14	828	330	405	320	250	125	95	180	225	100	80	580	510	970	192,5
CNG 80 160C	125	65	14	910	330	405	320	250	125	95	180	225	100	80	580	510	970	203
CNG 80 160B	125	65	14	910	330	405	320	250	125	95	180	225	100	80	650	570	1080	223,5
CNG 80 160A	125	65	14	955	330	405	320	250	125	95	180	225	100	80	650	570	1080	254
CNG 80 200B	125	65	18	1087	370	430	345	280	125	95	180	250	100	80	770	680	1300	327
CNG 80 200A	125	65	18	1087	370	430	345	280	125	95	180	250	100	80	770	680	1300	354
CNG 80 250C	125	80	18	1132	420	480	400	315	160	120	200	280	100	80	770	680	1300	454
CNG 80 250B	125	80	18	1260	420	480	400	315	160	120	200	280	100	80	770	680	1300	530
CNG 80 250A	125	80	18	1320	420	480	400	315	160	120	200	280	100	80	770	680	1300	681

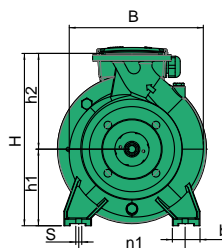
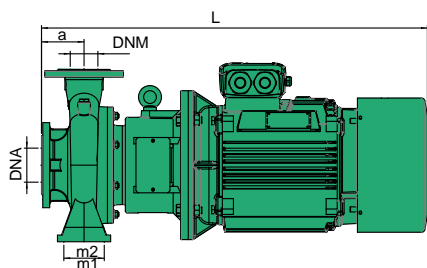

Flange - Flanges - Brides - Bridas
mm

DN	K	D	B	fori - holes - orifices - orificios	n°	∅
32	100	140	18	4	4	18
40	110	150	18	4	4	18
50	125	165	19	4	4	18
65	145	185	19	4	4	18
80	160	200	22	4	4	18
100	180	220	24	8	8	18

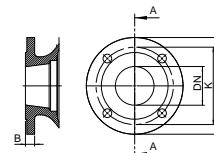

TIPO TYPE	DIMENSIONI [mm] DIMENSIONS [mm]														IMBALLO [mm] PACKING [mm]			PESO WEIGHT [kg]
	a	b	s	L	B	H	n1	n2	m1	m2	h1	h2	DNA	DNM	A	L	P	
CNG 32 160A 4	80	50	14	498	240	292	240	190	100	70	132	160	50	32	380	290	520	64,6
CNG 32 200B 4	80	50	14	497,5	273	340	240	190	100	70	160	180	50	32	420	360	760	82,1
CNG 32 200A 4	80	50	14	532,5	273	340	240	190	100	70	160	180	50	32	420	360	760	70
CNG 32 250C 4	100	65	14	553	326	405	320	250	125	95	180	225	50	32	580	510	970	91,5
CNG 32 250B 4	100	65	14	553	326	405	320	250	125	95	180	225	50	32	580	510	970	121
CNG 32 250A 4	100	65	14	592	326	405	320	250	125	95	180	225	50	32	580	510	970	119,5
CNG 40 125A 4	80	50	14	497,5	216	252	210	160	100	70	112	140	65	40	380	290	520	62,6
CNG 40 160A 4	80	50	14	498	242	292	240	190	100	70	132	160	65	40	380	290	520	69,2
CNG 40 200B 4	100	50	14	517,5	278	340	265	212	100	70	160	180	65	40	420	360	760	68,8
CNG 40 200A 4	100	50	14	552,5	278	340	265	212	100	70	160	180	65	40	420	360	760	72,5
CNG 40 250B 4	100	65	14	553	328	405	320	250	125	95	180	225	65	40	580	510	970	122,5
CNG 40 250A 4	100	65	14	592	328	405	320	250	125	95	180	225	65	40	580	510	970	121
CNG 50 125A 4	100	50	14	517,5	248	292	240	190	100	70	132	160	65	50	380	290	520	69,2
CNG 50 160B 4	100	50	14	518	268	340	265	212	100	70	160	180	65	50	420	360	760	65,3
CNG 50 160A 4	100	50	14	553	268	340	265	212	100	70	160	180	65	50	420	360	760	69,5
CNG 50 200C 4	100	50	14	553	290	360	265	212	100	70	160	200	65	50	580	510	970	85,5
CNG 50 200B 4	100	50	14	553	290	360	265	212	100	70	160	200	65	50	580	510	970	115
CNG 50 200A 4	100	50	14	592	290	360	265	212	100	70	160	200	65	50	580	510	970	113,5
CNG 50 250C 4	100	65	14	553	334	405	320	250	125	95	180	225	65	50	580	510	970	115,5
CNG 50 250B 4	100	65	14	592	334	405	320	250	125	95	180	225	65	50	650	570	1080	127,5
CNG 50 250A 4	100	65	14	592	334	405	320	250	125	95	180	225	65	50	650	570	1080	116,5
CNG 65 125B 4	100	65	14	517,5	283	340	280	212	125	95	160	180	80	65	420	360	760	64,8
CNG 65 125A 4	100	65	14	552,5	283	340	280	212	125	95	160	180	80	65	420	360	760	69
CNG 65 160C 4	100	65	14	557	290	360	280	212	125	95	160	200	80	65	580	510	970	86,5
CNG 65 160B 4	100	65	14	557	290	360	280	212	125	95	160	200	80	65	580	510	970	116
CNG 65 160A 4	100	65	14	596	290	360	280	212	125	95	160	200	80	65	580	510	970	114,5
CNG 65 200C 4	100	65	14	557	330	405	320	250	125	95	180	225	80	65	580	510	970	112
CNG 65 200B 4	100	65	14	596	330	405	320	250	125	95	180	225	80	65	650	570	1080	123,5
CNG 65 200A 4	100	65	14	596	330	405	320	250	125	95	180	225	80	65	650	570	1080	112
CNG 65 250B 4	100	80	18	627	375	450	360	280	160	120	200	250	80	65	650	570	1080	120
CNG 65 250A 4	100	80	18	681	375	450	360	280	160	120	200	250	80	65	650	570	1080	145,4
CNG 80 125B 4	100	65	14	521,5	285	340	280	212	125	95	160	180	100	80	420	360	760	67,8
CNG 80 125A 4	100	65	14	556,5	285	340	280	212	125	95	160	180	100	80	420	360	760	72
CNG 80 160D 4	125	65	14	582	330	405	320	250	125	95	180	225	100	80	580	510	970	118
CNG 80 160C 4	125	65	14	582	330	405	320	250	125	95	180	225	100	80	580	510	970	113,5
CNG 80 160B 4	125	65	14	621	330	405	320	250	125	95	180	225	100	80	650	570	1080	125
CNG 80 160A 4	125	65	14	621	330	405	320	250	125	95	180	225	100	80	650	570	1080	113,5
CNG 80 200B 4	125	65	18	663	370	430	345	280	125	95	180	250	100	80	770	680	1300	128,5
CNG 80 200A 4	125	65	18	717	370	430	345	280	125	95	180	250	100	80	770	680	1300	153,9
CNG 80 250C 4	125	80	18	717	420	480	400	315	160	120	200	280	100	80	770	680	1300	187,9
CNG 80 250B 4	125	80	18	757	420	480	400	315	160	120	200	280	100	80	770	680	1300	176
CNG 80 250A 4	125	80	18	757	420	480	400	315	160	120	200	280	100	80	770	680	1300	204

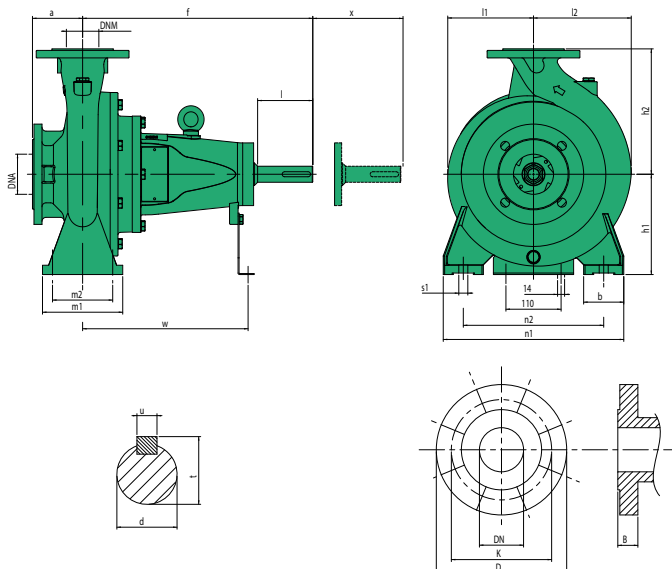

Flange - Flanges - Brides - Bidas
mm

DN	K	D	B	fori - holes - orifices - orificios	
				n°	Ø
32	100	140	18	4	18
40	110	150	18	4	18
50	125	165	19	4	18
65	145	185	19	4	18
80	160	200	22	4	18
100	180	220	24	8	18

Albero - Shaft - Abre - Eje
mm

d	l	u	t
24 j6	50	8	27
32 k6	80	10	35
42 k6	110	12	45

TIPO TYPE	DIMENSIONI [mm] DIMENSIONS [mm]																
	DNA	DNM	a	f	h1	h2	l1	l2	m1	m2	n1	n2	b	s1	d	w	x
BSN 32 125	50	32	80	356	112	140	102	102	100	70	190	140	50	14	24	254	100
BSN 32 160	50	32	80	360	132	160	116,5	116,5	100	70	240	190	50	14	24	254	100
BSN 32 200	50	32	80	356	160	180	140	140	100	70	240	190	50	14	24	254	100
BSN 32 250	50	32	100	360	180	225	166	166	125	95	320	250	65	14	24	254	100
BSN 40 125	65	40	80	356	112	160	116,5	116,5	100	70	240	190	50	14	24	254	100
BSN 40 160	65	40	80	360	132	160	116,5	121,5	100	70	240	190	50	14	24	254	100
BSN 40 200	65	40	100	356	160	180	140	140	100	70	265	212	50	14	24	254	100
BSN 40 250	65	40	100	360	180	225	166	166	125	95	320	250	65	14	24	254	100
BSN 50 125	65	50	100	356	132	160	101,5	112	100	70	210	190	50	14	24	254	100
BSN 50 160	65	50	100	356	160	180	120	136	100	70	265	212	50	14	24	254	100
BSN 50 200	65	50	100	360	160	200	140	150	100	70	265	212	50	14	24	254	100
BSN 50 250	65	50	100	360	180	225	166	170	125	95	320	250	65	14	24	254	100
BSN 65 125	80	65	100	356	160	180	112	143	125	95	280	212	65	14	24	254	100
BSN 65 160	80	65	100	365	160	200	123	148	125	95	280	212	65	14	24	258	100
BSN 65 200	80	65	100	365	180	225	147	168	125	95	320	250	65	14	24	258	140
BSN 65 250	80	65	100	460	200	250	170	195	160	120	360	280	80	18	32	330	140
BSN 80 125	100	80	100	360	160	180	120	145	125	95	280	212	65	14	24	258	100
BSN 80 160	100	80	125	365	180	225	135	170	125	95	320	250	65	14	24	258	140
BSN 80 200	100	80	125	470	180	250	165	195	125	95	350	280	65	18	32	340	140
BSN 80 250	100	80	125	470	200	280	195	218	160	120	400	315	80	18	32	340	140

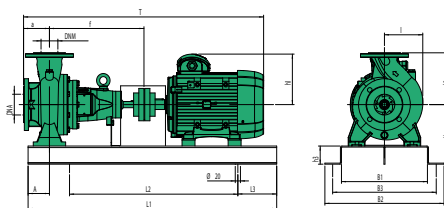

TIPO TYPE	MOTOR	DIMENSIONI [mm] DIMENSIONS [mm]															
		DNA	DNM	a	f	H	h1	h2	L1	L2	L3	B1	B2	B3	A	h3	T
BSN 32 125 B 2	80 B	50	32	80	356	176	129	140	800	600	100	300	360	336	65	64	731
33 125 A 2	90 S A	50	32	80	356	176	138	140	800	600	100	300	360	336	65	64	750
BSN 32 160 B 2	90 L C	50	32	80	360	196	138	160	800	600	100	300	360	336	65	64	778
32 160 A 2	100 L A	50	32	80	360	196	145	160	800	600	100	300	360	336	65	64	820
BSN 32 200 C 2	112 M A	50	32	80	356	224	161	180	800	600	100	300	360	336	65	64	825
32 200 B 2	132 S Y	50	32	80	356	240	198	180	990	790	100	392	460	430	82	80	905
32 200 A 2	132 S Z	50	32	80	356	240	198	180	990	790	100	392	460	430	82	80	905
BSN 32 250 C 2	132 M Z	50	32	100	360	260	198	225	990	790	100	392	460	430	82	80	930
32 250 B 2	160 M V	50	32	100	360	260	246	225	990	790	100	392	460	430	82	80	1090
32 250 A 2	160 M X	50	32	100	360	260	246	225	990	790	100	392	460	430	82	80	1090
BSN 40 125 C 2	90 S A	65	40	80	356	176	138	160	800	600	100	300	360	336	65	64	750
40 125 B 2	90 L C	65	40	80	356	176	138	160	800	600	100	300	360	336	65	64	780
40 125 A 2	100 L A	65	40	80	356	176	145	160	800	600	100	300	360	336	65	64	820
BSN 40 160 B 2	100 L A	65	40	80	360	196	145	160	800	600	100	300	360	336	65	64	820
40 160 A 2	112 M A	65	40	80	360	196	161	160	800	600	100	300	360	336	65	64	830
BSN 40 200 B 2	132 S Y	65	40	100	356	240	198	180	990	790	100	392	460	430	82	80	930
40 200 A 2	132 S Z	65	40	100	356	240	198	180	990	790	100	392	460	430	82	80	930
BSN 40 250 B 2	160 M V	65	40	100	360	260	246	225	990	790	100	392	460	430	82	80	1090
40 250 A 2	160 M X	65	40	100	360	260	246	225	990	790	100	392	460	430	82	80	1090
BSN 50 125 C 2	90 L C	65	50	100	356	196	138	160	800	600	100	300	360	336	65	64	800
50 125 B 2	100 L A	65	50	100	356	196	145	160	800	600	100	300	360	336	65	64	840
50 125 A 2	112 M A	65	50	100	356	196	161	160	800	600	100	300	360	336	65	64	850
BSN 50 160 B 2	132 S Y	65	50	100	356	240	198	180	990	790	100	392	460	430	82	80	930
50 160 A 2	132 S Z	65	50	100	356	240	198	180	990	790	100	392	460	430	82	80	930
BSN 50 200 C 2	132 M Z	65	50	100	360	240	198	200	990	790	100	392	460	430	80	80	930
50 200 B 2	160 M V	65	50	100	360	240	246	200	990	790	100	392	460	430	80	80	1090
50 200 A 2	160 M X	65	50	100	360	240	246	200	990	790	100	392	460	430	80	80	1090
BSN 50 250 C 2	160 M X	65	50	100	360	260	246	225	990	790	100	392	460	430	82	80	1090
50 250 B 2	160 L X	65	50	100	360	260	246	225	990	790	100	392	460	430	82	80	1140
50 250 A 2	180 M X	65	50	100	360	260	266	225	990	790	100	392	460	430	82	80	1170
BSN 65 125 B 2	132 S Y	80	65	100	356	240	198	180	990	790	100	392	460	430	82	80	925
65 125 A 2	132 S Z	80	65	100	356	240	198	180	990	790	100	392	460	430	82	80	925
BSN 65 160 C 2	132 M Z	80	65	100	365	240	198	200	990	790	100	392	460	430	82	80	935
65 160 B 2	160 M V	80	65	100	365	240	246	200	990	790	100	392	460	430	82	80	1090
65 160 A 2	160 M X	80	65	100	365	240	246	200	990	790	100	392	460	430	82	80	1090
BSN 65 200 C 2	160 M X	80	65	100	365	260	246	225	990	790	100	392	460	430	82	80	1090
65 200 B 2	160 L X	80	65	100	365	260	246	225	990	790	100	392	460	430	82	80	1140
65 200 A 2	180 M X	80	65	100	365	260	266	225	990	790	100	392	460	430	82	80	1170
BSN 65 250 B 2	200 L L	80	65	100	460	350	341	250	1250	990	130	-	500	460	130	150	1340
65 250 A 2	200 L N	80	65	100	460	350	341	250	1250	990	130	-	500	460	130	150	1340
BSN 80 125 B 2	132 S Y	100	80	100	360	240	198	180	990	790	100	392	460	430	82	80	930
80 125 A 2	132 S Z	100	80	100	360	240	198	180	990	790	100	392	460	430	82	80	930
BSN 80 160 D 2	160 M V	100	80	125	365	260	246	225	990	790	100	392	460	430	82	80	1115
80 160 C 2	160 M X	100	80	125	365	260	246	225	990	790	100	392	460	430	82	80	1115
80 160 B 2	160 L X	100	80	125	365	260	246	225	990	790	100	392	460	430	82	80	1170
80 160 A 2	180 M X	100	80	125	365	260	266	225	990	790	100	392	460	430	82	80	1200
BSN 80 200 B 2	200 L L	100	80	125	470	350	341	250	1250	990	130	-	500	460	130	150	1380
80 200 A 2	200 L N	100	80	125	470	350	341	250	1250	990	130	-	500	460	130	150	1380
BSN 80 250 C 2	225 M N	100	80	125	470	375	360	280	1290	1030	130	-	500	460	130	150	1410
80 250 B 2	225 M N	100	80	125	470	400	390	280	1390	1130	130	-	600	560	130	150	1520
80 250 A 2	280 S T	100	80	125	470	430	423	280	1400	1270	130	-	600	560	130	150	1590

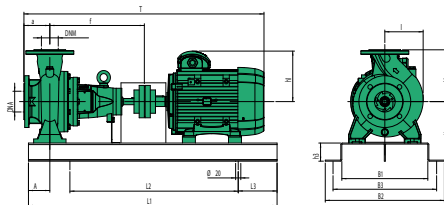

TIPO TYPE	MOTOR	DIMENSIONI [mm] DIMENSIONS [mm]															
		DNA	DNM	a	f	H	h1	h2	L1	L2	L3	B1	B2	B3	A	h3	T
BSN 32 125 B 4	71	50	32	80	356	176	112	140	800	600	100	300	360	336	65	64	690
33 125 A 4	71	50	32	80	356	176	112	140	800	600	100	300	360	336	65	64	690
BSN 32 160 B 4	71	50	32	80	360	196	112	160	800	600	100	300	360	336	65	64	690
32 160 A 4	80	50	32	80	360	196	129	160	800	600	100	300	360	336	65	64	730
BSN 32 200 C 4	80	50	32	80	356	224	129	180	800	600	100	300	360	336	65	64	730
32 200 B 4	80	50	32	80	356	224	129	180	800	600	100	300	360	336	65	64	730
32 200 A 4	90 S	50	32	80	356	224	138	180	800	600	100	300	360	336	65	64	750
BSN 32 250 C 4	90 S	50	32	100	360	244	138	225	800	600	100	350	410	386	78	64	775
32 250 B 4	90 L	50	32	100	360	244	138	225	800	600	100	350	410	386	78	64	805
32 250 A 4	100 L	50	32	100	360	244	145	225	800	600	100	350	410	386	78	64	840
BSN 40 125 C 4	71	65	40	80	356	176	112	160	800	600	100	300	360	336	65	64	690
40 125 B 4	71	65	40	80	356	176	112	160	800	600	100	300	360	336	65	64	730
40 125 A 4	80	65	40	80	356	176	129	160	800	600	100	300	360	336	65	64	730
BSN 40 160 B 4	71	65	40	80	360	196	112	160	800	600	100	300	360	336	65	64	690
40 160 A 4	80	65	40	80	360	196	129	160	800	600	100	300	360	336	65	64	730
BSN 40 200 B 4	80	65	40	100	356	224	129	180	800	600	100	350	410	386	65	64	750
40 200 A 4	90 S	65	40	100	356	224	138	180	800	600	100	350	410	386	65	64	770
BSN 40 250 B 4	90 L	65	40	100	360	244	138	225	800	600	100	350	410	386	78	64	805
40 250 A 4	100 L	65	40	100	360	244	145	225	800	600	100	350	410	386	78	64	845
BSN 50 125 C 4	71	65	50	100	356	196	112	160	800	600	100	300	360	336	65	64	710
50 125 B 4	71	65	50	100	356	196	112	160	800	600	100	300	360	336	65	64	710
50 125 A 4	80	65	50	100	356	196	129	160	800	600	100	300	360	336	65	64	750
BSN 50 160 B 4	80	65	50	100	356	224	129	180	800	600	100	350	410	386	65	64	750
50 160 A 4	90 S	65	50	100	356	224	138	180	800	600	100	350	410	386	65	64	770
BSN 50 200 C 4	90 S	65	50	100	360	224	138	200	800	600	100	350	410	386	65	64	775
50 200 B 4	90 L	65	50	100	360	224	138	200	800	600	100	350	410	386	65	64	805
50 200 A 4	100 L	65	50	100	360	224	145	200	800	600	100	350	410	386	65	64	820
BSN 50 250 C 4	90 L	65	50	100	360	244	138	225	800	600	100	350	410	386	78	64	805
50 250 B 4	100 L	65	50	100	360	244	145	225	800	600	100	350	410	386	78	64	845
50 250 A 4	100 L	65	50	100	360	244	145	225	800	600	100	350	410	386	78	64	845
BSN 65 125 B 4	80	80	65	100	356	224	129	180	800	600	100	350	410	386	78	64	750
65 125 A 4	90 S	80	65	100	356	224	138	180	800	600	100	350	410	386	78	64	770
BSN 65 160 C 4	90 S	80	65	100	365	224	138	200	800	600	100	350	410	386	78	64	780
65 160 B 4	90 L	80	65	100	365	224	138	200	800	600	100	350	410	386	78	64	810
65 160 A 4	100 L	80	65	100	365	224	145	200	800	600	100	350	410	386	78	64	850
BSN 65 200 C 4	90 L	80	65	100	365	244	138	225	800	600	100	350	410	386	78	64	810
65 200 B 4	100 L	80	65	100	365	244	145	225	800	600	100	350	410	386	78	64	850
65 200 A 4	100 L	80	65	100	365	244	145	225	800	600	100	350	410	386	78	64	850
BSN 65 250 B 4	112 M	80	65	100	460	280	161	250	990	790	100	-	500	470	90	80	950
65 250 A 4	132 S	80	65	100	460	280	198	250	990	790	100	-	500	470	90	80	1030
BSN 80 125 B 4	80	100	80	100	360	224	129	180	800	600	100	350	410	386	78	64	750
80 125 A 4	90 S	100	80	100	360	224	138	180	800	600	100	350	410	386	78	64	775
BSN 80 160 D 4	90 S	100	80	125	365	244	138	225	800	600	100	350	410	386	78	64	805
80 160 C 4	90 L	100	80	125	365	244	138	225	800	600	100	350	410	386	78	64	835
80 160 B 4	100 L	100	80	125	365	244	145	225	800	600	100	350	410	386	78	64	870
80 160 A 4	100 L	100	80	125	365	244	145	225	800	600	100	350	410	386	78	64	870
BSN 80 200 B 4	112 M	100	80	125	470	260	161	250	990	790	100	-	500	470	78	80	990
80 200 A 4	132 S	100	80	125	470	260	198	250	990	790	100	-	500	470	78	80	1060
BSN 80 250 C 4	132 S	100	80	125	470	280	198	280	990	790	100	-	500	470	90	80	1060
80 250 B 4	132 M	100	80	125	470	280	198	280	990	790	100	-	500	470	90	80	1060
80 250 A 4	132 M	100	80	125	470	280	198	280	990	790	100	-	500	470	90	80	1060

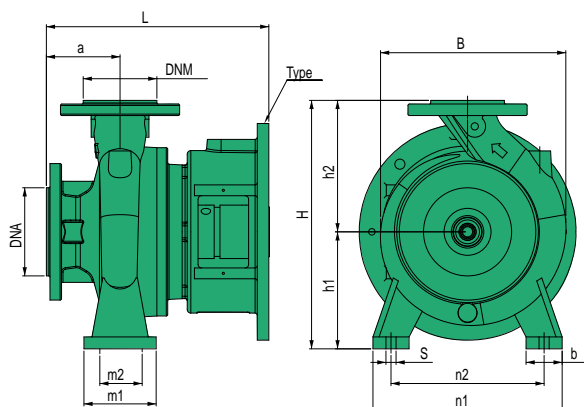

Flange - Flanges - Brides - Bridas
mm

DN	K	D	B	fori - holes - orifices - orificios	
				n°	Ø
32	100	140	18	4	18
40	110	150	18	4	18
50	125	165	19	4	18
65	145	185	19	4	18
80	160	200	22	4	18
100	180	220	24	8	18

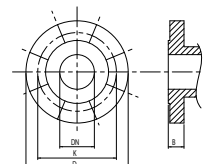

TIPO TYPE	DIMENSIONI [mm] DIMENSIONS [mm]											Motor MEC Size Motor		Flangia Coupling		IMBALLO [mm] PACKING [mm]			
	a	b	s	L	B	H	n1	n2	m1	m2	h1	h2	DNA	DNM	Type	Type	A	L	P
ING 32 200B	80	50	14	286	273	340	240	190	100	70	160	180	50	32	132	B5	410	550	320
ING 32 200A	80	50	14	286	273	340	240	190	100	70	160	180	50	32	132	B5	410	550	320
ING 32 250C	100	65	14	341	326	405	320	250	125	95	180	225	50	32	132	B5	410	550	320
ING 32 250B	100	65	14	341	326	405	320	250	125	95	180	225	50	32	160	B5	440	630	360
ING 32 250A	100	65	14	341	326	405	320	250	125	95	180	225	50	32	160	B5	440	630	360
ING 40 200B	100	50	14	307	278	340	265	212	100	70	160	180	65	40	132	B5	410	550	320
ING 40 200A	100	50	14	307	278	340	265	212	100	70	160	180	65	40	132	B5	410	550	320
ING 40 250B	100	65	14	343	328	405	320	250	125	95	180	225	65	40	160	B5	440	630	360
ING 40 250A	100	65	14	343	328	405	320	250	125	95	180	225	65	40	160	B5	440	630	360
ING 50 160B	100	50	14	306	268	340	265	212	100	70	160	180	65	50	132	B5	410	550	320
ING 50 160A	100	50	14	306	268	340	265	212	100	70	160	180	65	50	132	B5	410	550	320
ING 50 200C	100	50	14	342	290	360	265	212	100	70	160	200	65	50	132	B5	410	550	320
ING 50 200B	100	50	14	342	290	360	265	212	100	70	160	200	65	50	160	B5	440	630	360
ING 50 200A	100	50	14	342	290	360	265	212	100	70	160	200	65	50	160	B5	440	630	360
ING 50 250C	100	65	14	342	334	405	320	250	125	95	180	225	65	50	160	B5	440	630	360
ING 50 250B	100	65	14	342	334	405	320	250	125	95	180	225	65	50	160	B5	440	630	360
ING 50 250A	100	65	14	342	334	405	320	250	125	95	180	225	65	50	180	B5	440	630	360
ING 65 125B	100	65	14	310	283	340	280	212	125	95	160	180	80	65	132	B5	410	550	320
ING 65 125A	100	65	14	310	283	340	280	212	125	95	160	180	80	65	132	B5	410	550	320
ING 65 160C	100	65	14	347	290	360	280	212	125	95	160	200	80	65	132	B5	410	550	320
ING 65 160B	100	65	14	347	290	360	280	212	125	95	160	200	80	65	160	B5	440	630	360
ING 65 160A	100	65	14	347	290	360	280	212	125	95	160	200	80	65	160	B5	440	630	360
ING 65 200C	100	65	14	349	330	405	320	250	125	95	180	225	80	65	160	B5	440	630	360
ING 65 200B	100	65	14	349	330	405	320	250	125	95	180	225	80	65	160	B5	440	630	360
ING 65 200A	100	65	14	349	330	405	320	250	125	95	180	225	80	65	180	B5	440	630	360
ING 65 250B	100	80	18	350	375	450	360	280	160	120	200	250	80	65	200	B5	500	500	500
ING 65 250A	100	80	18	350	375	450	360	280	160	120	200	250	80	65	200	B5	500	500	500
ING 80 125B	100	65	14	311	285	340	280	212	125	95	160	180	100	80	132	B5	410	550	320
ING 80 125A	100	65	14	311	285	340	280	212	125	95	160	180	100	80	132	B5	410	550	320
ING 80 160D	125	65	14	373	330	405	320	250	125	95	180	225	100	80	160	B5	440	630	360
ING 80 160C	125	65	14	373	330	405	320	250	125	95	180	225	100	80	160	B5	440	630	360
ING 80 160B	125	65	14	373	330	405	320	250	125	95	180	225	100	80	160	B5	440	630	360
ING 80 160A	125	65	14	373	330	405	320	250	125	95	180	225	100	80	180	B5	440	630	360
ING 80 200B	125	65	18	394	370	430	345	280	125	95	180	250	100	80	200	B5	500	500	500
ING 80 200A	125	65	18	394	370	430	345	280	125	95	180	250	100	80	200	B5	500	500	500
ING 80 250C	125	80	18	423	420	480	400	315	160	120	200	280	100	80	200	B5	500	500	500
ING 80 250B	125	80	18	423	420	480	400	315	160	120	200	280	100	80	250	B5	500	500	500
ING 80 250A	125	80	18	423	420	480	400	315	160	120	200	280	100	80	280	B5	500	500	500